

DAIKIN

PCSAU1439



SkyAir

Air Conditioning System

HEAT PUMP [50Hz]

Super Inverter

Inverter series



R-410A

PRODUCT RANGE



Series	50	60	71	
CEILING MOUNTED CASSETTE TYPE <i>< Round Flow ></i> 	NEW  FCQ50KAVEA Outdoor unit: RZQS50AV1	NEW  FCQ60KAVEA Outdoor unit: RZQS60AV1	NEW  FCQ71KAVEA Outdoor unit: RZQS71AV1	
	CEILING SUSPENDED TYPE Indoor unit: FHC50KAVEA Outdoor unit: RZQS50AV1		NEW  FHQ71BWV1A Outdoor unit: RZQS71AV1	
WALL MOUNTED TYPE Indoor unit: FAW50CWEA Outdoor unit: RZQS50AV1			 FAQ71CWEA Outdoor unit: RZQS71AV1	
	OUTDOOR UNIT Outdoor unit: RZQS50AV1		NEW  Outdoor unit: RZQS60AV1	NEW  Outdoor unit: RZQS71AV1

Inverter series

Series	50	60	71	
CEILING MOUNTED CASSETTE TYPE <i>< Round Flow ></i> 			NEW  FCQ71KAVEA Outdoor unit: RZQ71LV1	
	OUTDOOR UNIT Outdoor unit: RZQ71LV1		NEW  Outdoor unit: RZQ71LV1	







	100		125		140	
	 <p>NEW FCQ100KAVEA</p>		 <p>NEW FCQ125KAVEA</p>		 <p>NEW FCQ140KAVEA</p>	
	RZQS100AV1	RZQS100AY1	RZQS125AV1	RZQS125AY1	RZQS140AV1	RZQS140AY1
	 <p>NEW FHQ100BWV1A</p>		 <p>NEW FHQ125BWV1A</p>		 <p>NEW FHQ140CAVEA</p>	
	RZQS100AV1	RZQS100AY1	RZQS125AV1	RZQS125AY1	RZQS140AV1	RZQS140AY1
	 <p>NEW FAQ100CVEA</p>					
	RZQS100AV1	RZQS100AY1				
	 <p>NEW RZQS100AV1</p>	 <p>NEW RZQS100AY1</p>	 <p>NEW RZQS125AV1</p>	 <p>NEW RZQS125AY1</p>	 <p>NEW RZQS140AV1</p>	 <p>NEW RZQS140AY1</p>
	RZQS100AV1	RZQS100AY1	RZQS125AV1	RZQS125AY1	RZQS140AV1	RZQS140AY1

Page 7

Page 11

Page 13

Page 15

	100		125		140	
	 <p>NEW FCQ100KAVEA</p>		 <p>NEW FCQ125KAVEA</p>		 <p>NEW FCQ140KAVEA</p>	
	RZQ100LV1		RZQ125LV1		RZQ140LV1	
	 <p>NEW RZQ100LV1</p>		 <p>NEW RZQ125LV1</p>		 <p>NEW RZQ140LV1</p>	
	RZQ100LV1		RZQ125LV1		RZQ140LV1	

Page 7

Page 15



Energy Efficient

Super Inverter

Achieved higher COP

Complies with MEPS

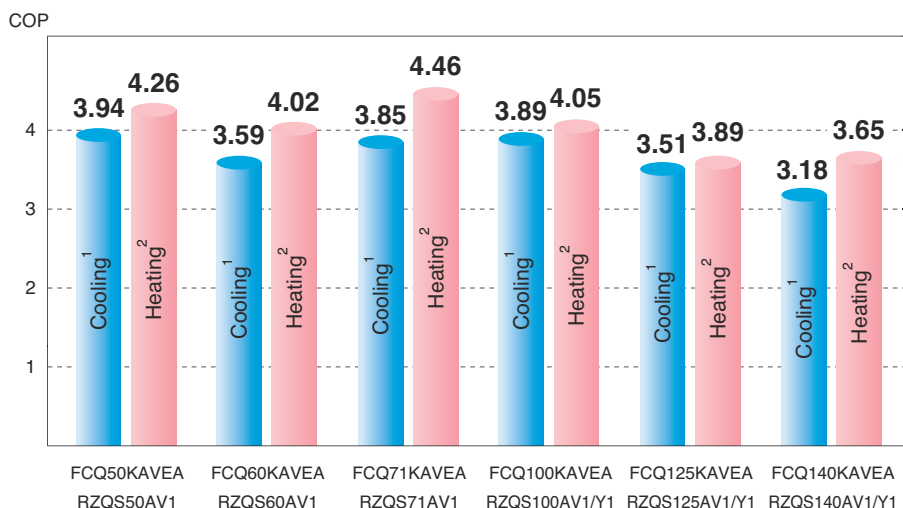

CEILING MOUNTED CASSETTE TYPE

〈 Round Flow 〉

Note :
¹Rated cooling capacities are based on the following conditions: Indoor temp., 27°CDB, 19.0°CWB; outdoor temp. 35°CDB, 24.0°CWB. Equiv. refrigeration piping, 7.5 m (horizontal).
²Rated heating capacities are based on the following conditions: Indoor temp., 20°CDB, outdoor temp., 7°CDB, 6°CWB. Equiv. refrigeration piping, 7.5 m (horizontal)

What is COP (Coefficient of Performance)

COP is equal to capacity (kW) divided by power consumption (kW), and the larger the COP value, the higher the energy efficiency, enabling cooling and heating with less electricity and increasing the energy saving performance.

High COP models

CEILING MOUNTED CASSETTE TYPE 〈 Round Flow 〉



	COP					
	50	60	71	100	125	140

Cooling	3.94	3.59	3.85	3.89	3.51	3.18
Heating	4.26	4.02	4.46	4.05	3.89	3.65

CEILING SUSPENDED TYPE

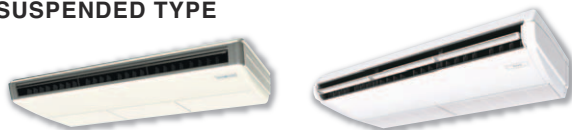

Cooling	—	—	3.28	3.23	3.15	3.04
Heating	—	—	3.23	3.22	3.10	3.24

WALL MOUNTED TYPE



Cooling	—	—	3.18	3.13	—	—
Heating	—	—	3.43	3.26	—	—

Compact and lightweight

Inverter series

Reduced installation work thanks to light, compact outdoor unit.

Height 1,170 mm	→	990 mm
Weight 98 kg	→	75 kg



RQ100LV1A



RZQ100LV1

990 mm

Reduced by
180 mm
Reduced by
23 kg

"Nav Ease"

Super Inverter

Inverter series

Wired Remote Controller

Clear Display

- Dot matrix display
- Backlight display

Simple operation

- Large buttons and arrow keys
- Guide on display

Energy saving

- NEW** • Setpoint range set
- NEW** • Setpoint auto reset
- Off timer (programmed)

Convenience

- Weekly schedule
- Multilingual display



Wired Remote Controller
BRC1E62

Comfortable

Super Inverter

Inverter series

Enhanced comfort with Inverter

Inverter performs variable control of frequency, which determines air conditioner's power performance.

At startup, full power is used to achieve the set temperature quickly. Then, the capacity is adjusted according to the outdoor temperature changes and subtle indoor load changes to achieve fine capacity control resulting in a more stable room temperature.

Non-inverter type air conditioners must be switched on and off repeatedly, causing large fluctuations of the room temperature.

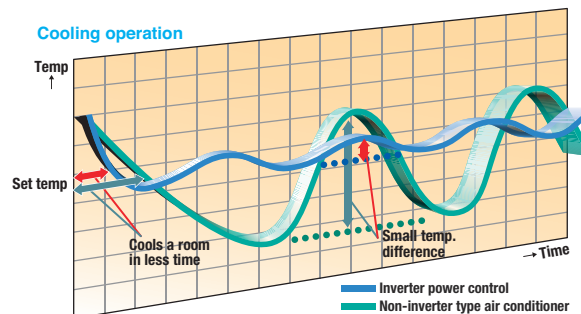

Soft starter is unnecessary, making electrical installation work much simpler.

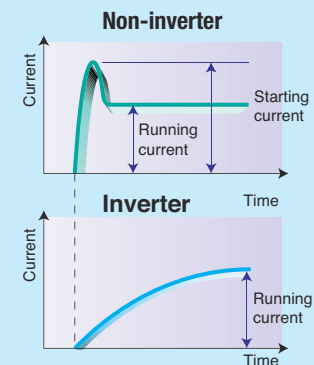

At startup, inverter raises frequency smoothly, eliminating the starting current spike.

Quiet operation

Super Inverter

Inverter series

Night quiet operation function

The Automatic night quiet mode will initiate 8 hours after the peak temperature is reached in the daytime, and normal operation will resume 10 hours after that.

★ Reducing noise will reduce capacity slightly.

Note :
³ Anechoic chamber conversion value, measured according to JIS parameters and criteria. During operation these values are somewhat higher owing to ambient conditions.
⁴ Value when cooling. Value will differ when heating.

Super Inverter

Inverter series

	Sound pressure level ³ (dB(A))	
	Rated ⁴	Night Quiet Mode
RZQS50/60AV1	48	44
RZQS71AV1	50	46
RZQS100AV1/Y1	53	49
RZQS125AV1/Y1	54	50
RZQS140AV1/Y1	54	50
RZQ71LV1	49	45
RZQ100/125LV1	51	47
RZQ140LV1	54	50

Reuse of existing piping

Benefit1 Reduces replacement time & cost by simplified installation

When considering air conditioner replacement, do the following things concern you?

- For how long will the business have to close down? While replacement work is going on, how will sales be affected?
- How to minimize inconvenience to tenants, who only leave the space vacant on weekends?
- Won't the costs be high and work period longer because scaffolding is necessary for pipe replacement?

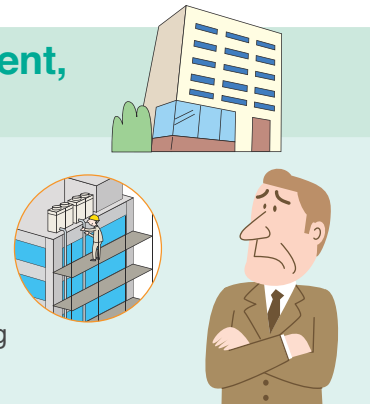

These problems are

solved by Daikin!

Where feasible, by reusing existing pipes*, we cut your work cost and reduce work time.

Normally, when you replace air conditioners, in addition to replacing indoor and outdoor units, replacement of piping involves high costs and lengthy work periods. And, the more installed units you have, the greater the cost for connecting them, especially if they are installed in high places or embedded. Leave it to Daikin! Since Daikin can carry out upgrades using your existing piping, you can get the work done faster than ever before.



*Strict conditions must be adhered to, please refer to the installation manual and Engineering Data Book for further details including pipe sizes (if pipes are to be re-used)

Benefit2 Enables Increased capacity & Higher EER/COP

Upgrade to air conditioners featuring the latest technology and enjoy greatly improved energy efficiency.

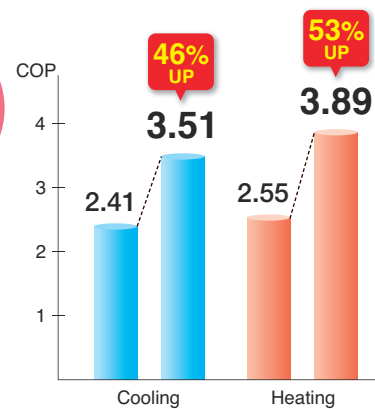

For example, compared with R22 non-inverter units of 15 years ago, in the latest R410A series some units use smaller diameter piping which means they can achieve greater cooling capacity by reusing existing piping. As a result, the greater capacity units ensure better performance to cope with the increasing amount of heat generated by office equipment.

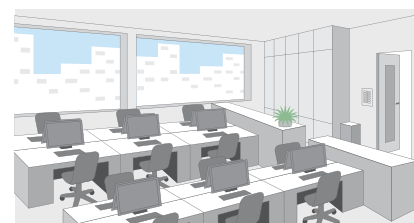

Simplified Installation

Enables simplified air conditioner replacement with minimal impact on operations.

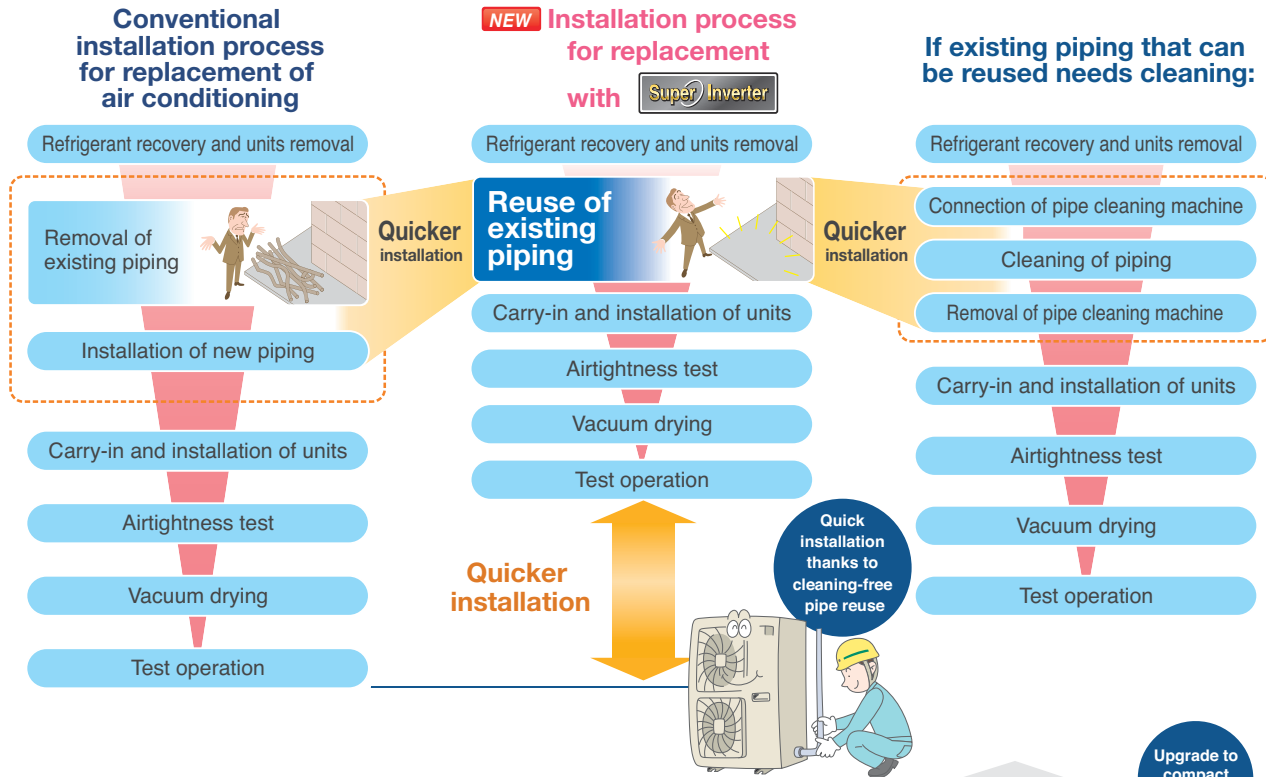

Particularly convenient in these circumstances

- Pipes are buried and making new pipe installations difficult.
- Outdoor unit difficult to access.
- Multiple units are being upgraded at the same time.

Piping left as is

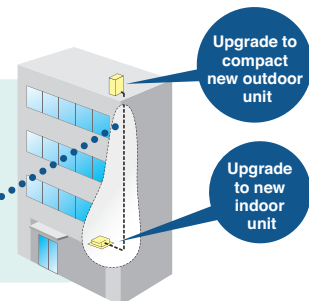

Technology

Advanced technology including use of corrosion resistant EEV, acid neutralisers and improved compressor reliability enables the re-use of existing piping* without the need to flush the piping for a simplified replacement process.

Stronger refrigerating machine oil

An acid neutraliser agent is added to disable acids (chlorine ions), which cause corrosion.

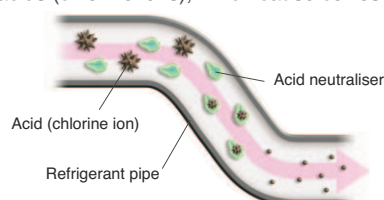

Highly corrosion resistant electronic expansion valve

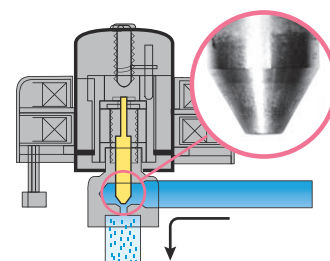

Highly reliable compressor

Durability of compressor is improved by adoption of filter or accumulator to collect solid foreign substances.

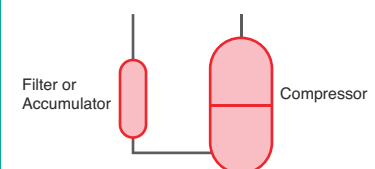

*Strict conditions must be adhered to, please refer to the installation manual and Engineering Data Book for further details including pipe sizes (if pipes are to be re-used)

Uniform 360° airflow cassette air conditioner is setting tomorrow's standards.



Heat pump
FCQ50/60/71/100/125/140KA

Accessory required for indoor unit

Wired LCD remote controller



"Nav Ease"
BRC1E62

Note: Remote controller cable not included. Cables must be procured locally.

Option

Wireless LCD remote controller

A signal receiver must be added to the indoor unit.



BRC7F634F

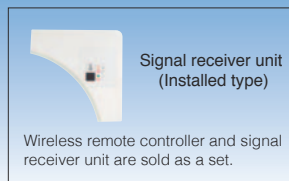

Signal receiver unit
(Installed type)

Wireless remote controller and signal receiver unit are sold as a set.

Features

Comfort				Remote controller		Cleanliness	Work & Servicing				Control features				Options	Others																		
Auto swing	Swing pattern selection	Draft prevention function (heating)	Switchable fan speed (3 step)	Programme "Dry"	High ceiling application	Two selectable temperature-sensors	Hot start (after defrost)	Year-round cooling applicable	Night quiet operation	Setpoint auto reset	Setpoint range set	Weekly schedule timer	Off timer (programmed)	Anti-bacterial air filter	Silver ion anti-bacterial drain pan	Drain pump mechanism	Pre-charged for up to 30 m	Filter sign	Ceiling soiling prevention	Low gas pressure detection	Emergency operation	Self-diagnosis function	Auto-restart	Auto-cooling/heating change-over	Control by 2 remote controllers	Group control by 1 remote controller	External command control	Central remote control	Interlock control	DLI-NET communication standard	High-efficiency filter	Fresh air intake kit	Anti-corrosion treated heat exchangers	
•	•	•	•	•	•	*1	•	•	*2	*1	*1	*1	*1	•	•	•	*2	•	•	•	•	•	•	•	•	•	*3	•	•	•	•	•	•	*2

*1 Applicable when wired remote controller is used

*2 For the outdoor units

*3 Option

Avoids uneven temperature and discomfort caused by drafts.

Comfort enhanced by Round Flow!

360° airflow

- With uniform temperature distribution



Airflow distribution creates uniform comfort throughout the space

Air movement is gentle with Round Flow

- Enhanced Comfort



360° airflow can maintain comfort even if air discharge speed is lower.

If you raise the set temperature by 1 to 1.5°C in cooling (and lower in heating), and velocity is decreased by 25%, you still obtain the same feeling temperature and comfort.

Adapts easily to the installation space.

- As air flows out from corner outlets, comfort spreads more evenly.

Typical flow patterns There are a total of 23 flow patterns.

All-round flow	3-way flow	L-shaped 2-way flow	Opposite 2-way flow
(E.g., installed in middle of ceiling) 4-way flow also possible.	(E.g., installed near a wall)	(E.g., installed in a corner)	(E.g., installed in a long room)

Note: Whatever the discharge direction, the same type of panel is used. If installing for other than all-round flow, an air discharge outlet sealing material (option) must be used to close each unused outlet.

Operation sound increases when using 2-way or 3-way flow.

Grime prevention and antibacterial coating: Makes cleaning easier.

External panels are treated with a coating that helps to repel dirt.

- To prevent dirt sticking to the external panels, they have been coated with a surface treatment.

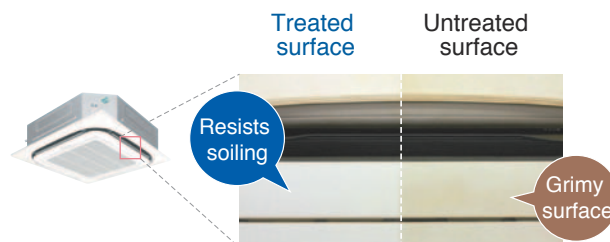

• Condition after exposure to the smoke of 600 cigarettes in 1 m³ enclosed space.

- Silver ion anti-bacterial drain pan

Mould-proof drain pan includes a silver ion antibacterial agent that assists in preventing the growth of slime, bacteria, and mould that cause smells and clogging.

- Non-flocking flaps

Condensation does not easily form on and dirt does not cling to non-flocking flaps. It is easy to clean.

- Filter has anti-mould and antibacterial treatment

Helps prevent mould and microorganisms growing out of the dust and moisture that adheres to the filters.

Unified square panels

- Panel size is the same for all models, FCQ50-140KA. It is easy to maintain a neat appearance when multiple units are installed in the same room.

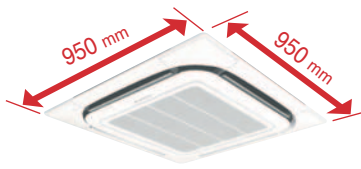

Same for all models

Compact body and quiet operation

Indoor unit	dB(A)		
	High	Middle	Low
50KA	35	31.5	28
60KA	35	31.5	28
71KA	35	31.5	28
100KA	43	37.5	32
125KA	44	39	34
140KA	44	40	36

Note: Anechoic chamber conversion value, measured according to JIS parameters and criteria. During operation these values are somewhat higher owing to ambient conditions.

Optimal comfort and convenience assured by 2 air discharge modes

Air direction	Standard setting ¹	Setting to prevent soiling of ceiling ² (field setting)
Desired situation	Standard setting to prevent draft.	Recommended for shops with light coloured ceilings that must be kept spotless.
Auto-swing	Auto-swing between 15° and 60°	Auto-swing between 25° and 60°
5-levels air direction setting	Settable to 5 different levels between 15° and 60°	Settable to 5 different levels between 25° and 60°
Draft prevention (In heating mode)	At heating startup and thermo OFF ³ , air discharge is automatically set to a near horizontal 25° or 30° to prevent direct exposure to cool air drafts.	
Auto air direction control	The air direction is set automatically to the memorised position of the previous air direction.	

Note:
¹Air direction is set to the standard position when the unit is shipped from the factory. The position can be changed from the remote controller.
²Closing of the corner discharge outlets is recommended.
³When the thermostat turns off.

Suitable for high ceilings

Even in spaces with high ceilings, a comfortable airflow is carried down to the floor level.

Criteria for ceiling height and number of air discharge outlets (Ceiling height is reference value)

		Number of air discharge outlets used							
		50-71KA				100-140KA			
		All round flow	4-way flow	3-way flow	2-way flow	All round flow	4-way flow	3-way flow	2-way flow
Ceiling height	Standard	2.7 m	3.1 m	3.0 m	3.5 m	3.2 m	3.4 m	3.6 m	4.2 m
	High ceiling ①	3.0 m	3.4 m	3.3 m	3.8 m	3.6 m	3.9 m	4.0 m	4.2 m
	High ceiling ②	3.5 m	4.0 m	3.5 m	—	4.2 m	4.5 m	4.2 m	—

Note: Factory settings are for standard ceiling height and all-round flow. High ceiling settings (1) and (2) are set with the remote controller by field setting.

Two selectable temperature-sensors

Both indoor unit and wired remote controller (option (BRC1E62)) contain temperature-sensors. Temperature sensing can be set at the unit or, to further improve comfort level, closer to the target area at the wired remote control. This feature requires initial setting by the installer.

*Temperature-sensor on indoor unit must be used when the air conditioner is controlled from another room.
 **Wireless remote controller does not have a temperature-sensor.

Hot start (after defrost)

Switchable fan speed: High/Middle/Low

Control of airflow rate has been improved from 2-step to 3-step.

Quick and easy to install

- Just 256 mm high. Installable in tight ceiling spaces (50-71KA)

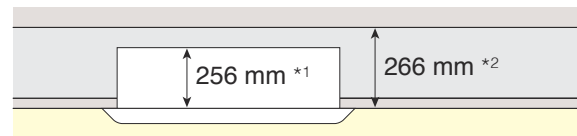

*1 298 mm high with 100-140KA
 *2 308 mm high with 100-140KA

Easy height adjustment

Each corner of the unit has an Adjuster Pocket that lets you easily adjust the unit's suspended height.

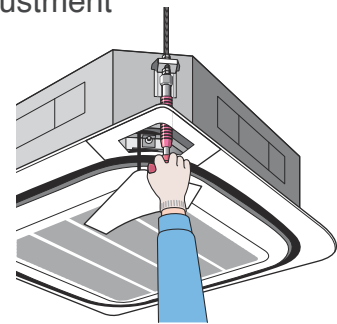

Note:
 If the wireless remote control option is installed, a light receptor unit is housed in one of the adjuster pockets.

- All models can be installed without using lifter because of the light weight.

Can be installed in any direction

Since the orientation of the intake grill can be adjusted after installing, the direction of the intake grill lines can be unified when multiple units are installed.

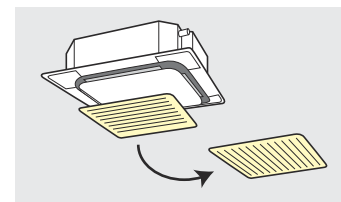

- Drain pump is equipped as standard accessory with 850 mm lift.

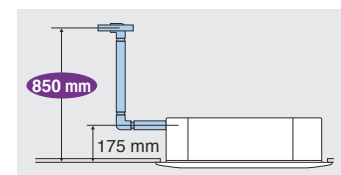

Transparent drain socket



- Connection to a centralised control system is available, no need for option card.

- Low gas pressure detection

Easier to maintain

- The condition of the drain pan and drain water can be checked by removing the drain plug and intake grille.

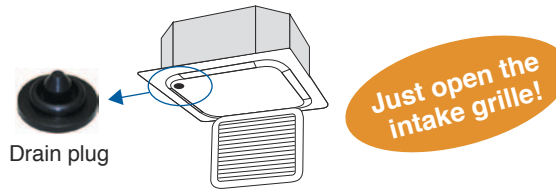

Options required for specific operating environments

High-efficiency filter

Available in two types: 65% and 90% colorimetry.

Fresh air intake kit

Using this kit, a duct can be fitted to increase the intake of outdoor air.

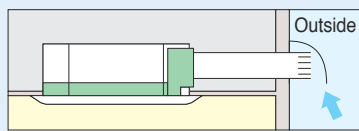

- Note: *Connecting ducts, insect nets, fire dampers, air filters, and other parts should, as required, be procured locally.
 **Outside Air fan interlocked with air conditioning unit is necessary. Optional PCB(KRP1C63)is required for interlocking.
 ***It is recommended that the volume of outdoor air introduced through the kit is limited to 10% of the maximum airflow rate of the indoor unit. Introducing higher quantities will increase the operating sound and may also influence temperature sending.

Panel spacer

Use when only minimal space is available between drop ceilings and ceiling slabs.

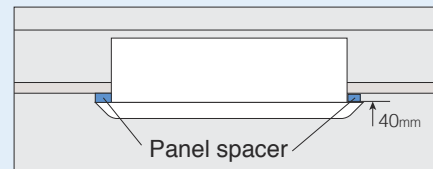

Note: Some ceiling constructions may hinder installation. Contact your Daikin Dealer before installing your unit.

Sealing material of air discharge outlet

Sealing material block air discharge openings not used in 2-way or 3-way blow.

Branch duct (direct-connection round duct)

A round duct can be attached without the need for a chamber.

A flanged port for direct connection of a round duct is provided. An existing branch duct chamber can also be fitted (square slit hole).

The units can be installed in the following different ways.

Chamber type

(without T-joint pipe and fan)

KDDP55B160

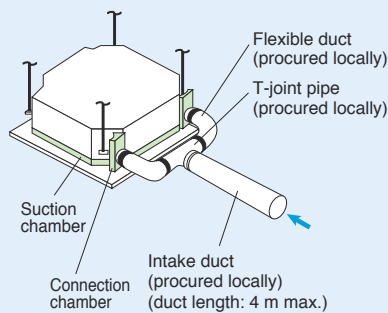

Chamber type

(with T-joint pipe and without fan)

KDDP55B160K

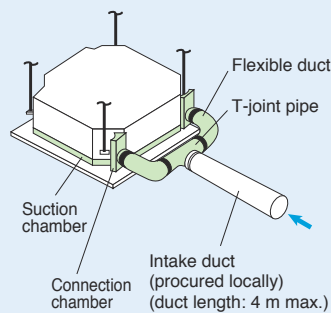

Direct installation type

KDDP55X160

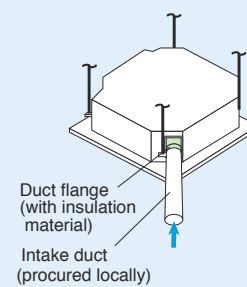

Note: Use of options will increase operating sound.

Comfortable airflow travels throughout the room



Heat pump

NEW FHQ71/100/125BW
FHQ140CA

FHQ71BW

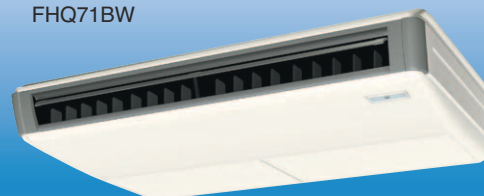

FHQ140CA



Accessory required for indoor unit

Wired Remote Controller



"Nav Ease"
BRC1E62

Note: Remote controller cable not included. Cables must be procured locally.

Option

Wireless LCD remote controller

A signal receiver must be added to the indoor unit.



71/100/125BW **BRC7EA63W**
140CA **BRC7GA53**



Signal receiver unit (Installed type)
Wireless remote controller and signal receiver unit are sold as a set.

Features

Comfort				Remote controller			Cleanliness	Work & Servicing				Control features					Options	Others											
Auto swing	Draft prevention function (heating)	Switchable fan speed	Programme "Dry"	High ceiling application	Two selectable temperature-sensors	Hot start (after defrost)	Year-round cooling applicable	Night quiet operation	Setpoint auto reset	Setpoint range set	Weekly schedule timer	Off timer (programmed)	Anti-bacterial air filter	Drain pump mechanism	Pre charged for up to 30 m	Filter sign	Low gas pressure detection	Emergency operation	Self-diagnosis function	Auto-restart	Auto-cooling/heating change-over	Control by 2 remote controllers	Group control by 1 remote controller	External command control	Central remote control	Interlock control	DLI-NET communication standard	Fresh air intake kit	Anti corrosion treated heat exchangers
●	●	*1	●	*2	*3	●	●	*4	*3	*3	*3	*3	●	*5	*4	●	*4	●	●	●	●	●	●	*5	*6	●	*7	*7	*4

*1FHQ71-125BW: 2 step, FHQ140CA: 3 step

*2Installable on max. 3.5 m (71-125BW), 4.3 m (140CA) high ceiling

*3Applicable when wired remote controller is used

*4For the outdoor units

*5Option

*6FHQ71-125BW: option required, FHQ140CA: standard

*7FHQ140CA only

■ New 140 model provides greater capacity for large spaces

- The technology of the DC fan motor, wide sirocco fan, and large heat exchanger combine for greater airflow and quiet operation.

High/Middle/Low : 46/42/38 dB(A)

- Sophisticated design

Flap neatly closes when not in use.

Fresh white colour.



- Installable on ceilings 4.3 m high

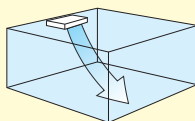

- 3 fan speeds: High/Middle/Low
- Connection to a centralised control system is available, no need for option card.
- Drain pump kit (option) includes a silver ion antibacterial agent that assists in preventing the growth of slime, bacteria, and mould that cause smells and clogging.

■ Comfortable

- Auto swing (up and down) and louvers (left and right by hand) bring comfort to the room

- Louver manually adjusts for straight or wide angle airflow

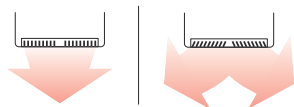

- Installable on ceilings 3.5 m high (FHQ71-125BW)

- Two selectable temperature-sensors

Both indoor unit and wired remote controller (option (BRC1E62)) contain temperature- sensors. Temperature sensing can be set at the unit or, to further improve comfort level, closer to the target area at the wired remote control. This feature requires initial setting by the installer.

*Temperature-sensor on indoor unit must be used when the air conditioner is controlled from another room.

**Wireless remote controller does not have a temperature-sensor.

- Switchable fan speed: High/Low (FHQ71-125BW)

- Programme "Dry"

Dehumidification is a microprocessor controlled to prevent abrupt and uncomfortable changes in air temperature.

■ Quiet operation

Indoor unit	dB(A)		
	High	Middle	Low
71BW	39	—	35
100BW	42	—	37
125BW	44	—	39
140CA	46	42	38

Note : Anechoic chamber conversion value, measured according to JIS parameters and criteria. During operation these values are somewhat higher owing to ambient conditions.

Uses quiet stream fan and other quiet technologies.

(FHQ71-125BW)

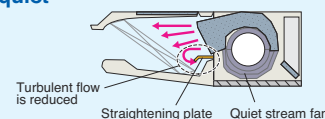

■ Installation flexibility for freedom of design

- Flexible installation

The unit fits more snugly into tight spaces.

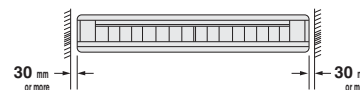

*Water used in the test-run can now be drained from the air discharge opening rather than from the side as was formerly the case.

- Drain pump kit (option) can be easily incorporated

Drain pipe connection can be done inside the unit. refrigerant and drain pipe outlets are at the same opening.

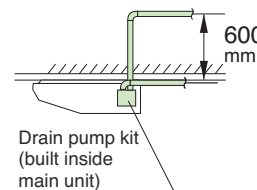

- All wiring and internal servicing can be done from under the unit

- Pipes more easily rigged

- Low gas pressure detection

■ Easy maintenance

- Non-flocking flap

Condensation does not easily form on and dirt does not cling to non-flocking flap. It is easy to clean.



- Easy-clean, flat surfaces

■ Oil resistant grille

- Oil-resistant plastic is used for the air suction grille. This satisfies durability in restaurants and other similar environments.

Note: Intended for use in salons, dining rooms, and ordinary sales floors, this specification is not suitable for kitchens or other harsh environments.

Compact design and easy installation



FAQ71/100C

FAQ71C



FAQ100C



Accessory required for indoor unit

Wired LCD remote controller



"Nav Ease"
BRC1E62

Note: Remote controller cable not included. Cables must be procured locally.

Option

Wireless LCD remote controller

A signal receiver must be added to the indoor unit.



BRC7EB518



Signal receiver unit (Installed type)
Wireless remote controller and signal receiver unit are sold as a set.

Features

Comfort							Remote controller				Cleanliness	Work & Servicing					Control features						Others							
Auto swing	Draft prevention function (heating)	Switchable fan speed (3 step)	Auto airflow rate	High fan speed mode	Programme "Dry"	Two selectable temperature-sensors	Hot start (after defrost)	Year-round cooling applicable	Night quiet operation	Setpoint auto reset	Setpoint range set	Weekly schedule timer	Off timer (programmed)	Mould-proof air filter	Drain pump mechanism	Pre-charged for up to 30 m	Filter sign	Low gas pressure detection	Emergency operation	Self-diagnosis function	Auto-restart	Auto-cooling/heating change-over	Control by 2 remote controllers	Group control by 1 remote controller	External command control	Central remote control	Interlock control	DLI-NET communication standard	Anti corrosion treated heat exchangers	
●	●	●	*1	●	●	*1	●	●	*2	*1	*1	*1	*1	●	*3	*2	●	*2	●	●	●	●	●	*3	●	●	●	●	●	*2

*1 Applicable when wired remote controller is used

*2 For the outdoor units

*3 Option

Compact & Sophisticated design

- FAQ100

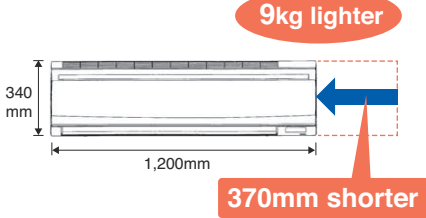

	FAQ100BV	FAQ100C
Height	360mm	340mm
Width	1,570mm	1,200mm
Depth	200mm	240mm
Weight	26kg	17kg

- Flaps neatly close when not in use



Comfortable

- Auto swing (up and down) and wide-angle louvers (left and right by hand) facilitate even room temperature

Wide-angle louvers (by hand)

Soft material louver bends airflow over a wider area

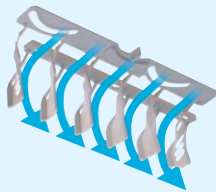

- An air discharge modes ensure comfortable air distribution across the entire room

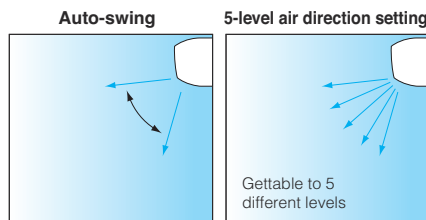

- Comfort even on the far side of the room

To carry air to the far side of long rooms, extra-high airflow adds 10% more fan speed the "high" setting. Air discharge setting is selected from the remote controller by field setting.

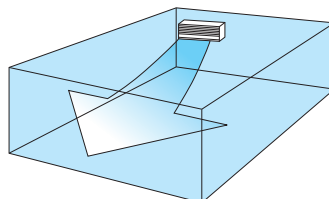

- Two selectable temperature-sensors
- Switchable fan speed: High/Middle/Low
- Auto airflow rate (When BRC1E62 is used)
- Programme "Dry"

Dehumidification is microprocessor controlled to prevent abrupt and uncomfortable changes in air temperature.

Easy installing and servicing

- 6-direction piping offers greater installation flexibility.

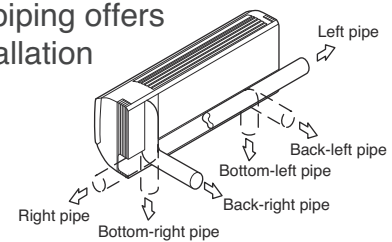

- Maintenance possible from the front of the unit

All maintenance tasks can be carried out via front access. During service work, attachment and detachment of parts is easier.

- Drain pump kit is available as option.

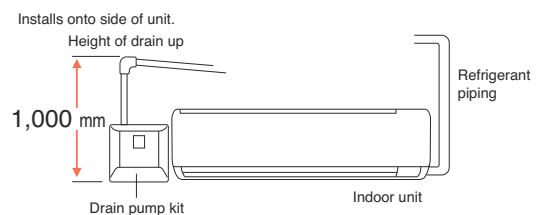

Drain pump kit can be installed on either left and right side of the air conditioner.



- Connection to a centralised control system is available, no need for option card.

Easy cleaning

- Removable and washable grille

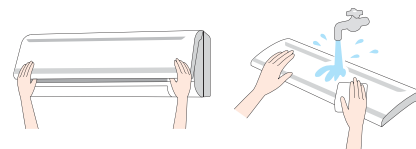

- Flat panel, easy to wipe dust off

- Non-flocking flaps

Condensation does not easily form on and dirt does not cling to non-flocking flaps. It is easy to clean.

OUTDOOR UNIT

Super Inverter



RZQS50AV1
RZQS60AV1

RZQS71AV1

RZQS100AV1/Y1
RZQS125AV1/Y1
RZQS140AV1/Y1

Inverter series



RZQ71LV1

RZQ100LV1

RZQ125LV1

RZQ140LV1

Easy installation and maintenance

Pre charged for up to 30 metres
If the refrigerant piping length does not exceed 30 m, there is no need for on-site gas charging.

75 m piping length

(Applicable to RZQS100-140A and RZQ100-140L outdoor units)

Allowed refrigerant piping length and level difference

	RZQS50-71A RZQ71L	RZQS100-140A RZQ100-140L
Pre charged ¹	30 m	
Max. length	50 m (Equivalent length 70m)	75 m (Equivalent length 90m)
Max. level difference	30 m	

Note : ¹ Additional refrigerant charging is required if the refrigerant pipe is longer than the length.

4-direction piping offers greater layout freedom

The outer panel for the piping connection part of the front, right side and backside can be removed and is easier for post-installation piping work.

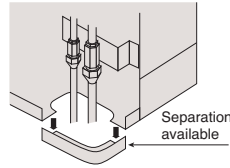

Facilitates pump down (Refrigerant recovery function)

A pump-down switch is provided to make it easier to collect refrigerant if the unit is to be moved or layout modified.

*Pump-down function is available for pre-charged refrigerant amount.

Low gas pressure detection function

Effective gas monitoring reduces the labor required for operation, maintenance, and repairs.

Operation range

Suited for year-round cooling applications

Cooling is efficient even in winter when indoor temperatures are higher than those outside, such as in underground public spaces or offices with many computers.

Wide operation range

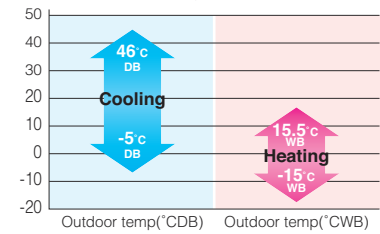

Compact and light weight

Reduced installation work thanks to light, compact outdoor unit.

Height 1,170 mm → **990 mm**
Weight 98 kg → **75 kg**

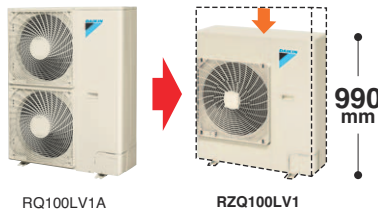

Reduced by **180 mm**
Reduced by **23 kg**

Durability

As the bottom frame is subject to corrosion, a corrosion-proof galvarium steel plate is adopted to enhance the durability.

Heat exchange fins are provided with anti-corrosion treatment

Construction

Non-treated fin ← Aluminium
Anti corrosion treated heat exchangers ← Hydrophilic film, ← Aluminium, ← Corrosion resistant acrylic resin

Night time quiet operation function

The Automatic night quiet mode will initiate 8 hours after the peak temperature is reached in the daytime, and normal operation will resume 10 hours after that.

★ Reducing noise will reduce capacity slightly.

	Sound pressure level ¹ (dB(A))		
	Rated ²	Night Quiet Mode	
Super Inverter	RZQS50/60AV1	48	44
	RZQS71AV1	50	46
	RZQS100AV1/Y1	53	49
	RZQS125AV1/Y1	54	50
	RZQS140AV1/Y1	54	50
Inverter series	RZQ71LV1	49	45
	RZQ100/125LV1	51	47
	RZQ140LV1	54	50

Note : ¹ Anechoic chamber conversion value, measured according to JIS parameters and criteria. During operation these values are somewhat higher owing to ambient conditions.

² Value when cooling. Value will differ when heating.

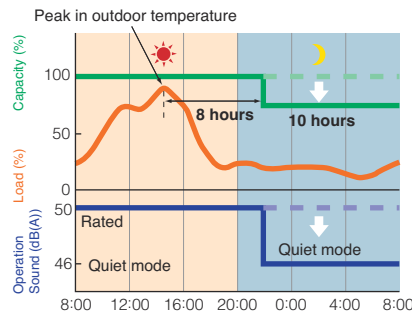

Note : ³ In case of RZQS71AV1

Demand Control Function

The maximum capacity is maintained within a set level of power consumption, which makes it possible to keep a comfortable and effective demand control.

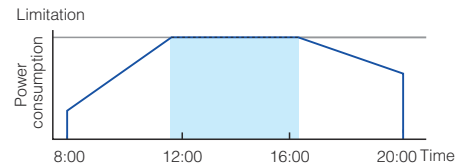

* Required for KRP58M51 (Option)

Technology for energy efficiency

The high efficiency compressor to achieve a high COP

1 Compressor equipped with Reluctance DC motor

Daikin DC Inverter models are equipped with the Reluctance DC motor for compressor.

The Reluctance DC motor uses 2 different types of torque, neodymium magnet*1 and reluctance torque*2.

This motor can save energy because it generates more power with a smaller electric power than an AC or conventional DC motor.

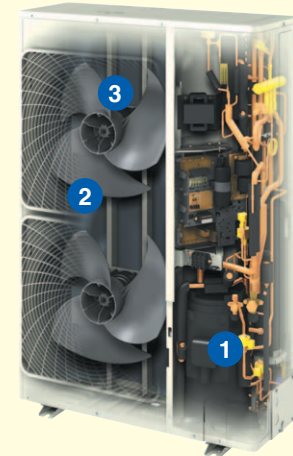
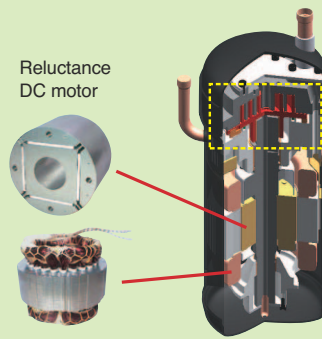
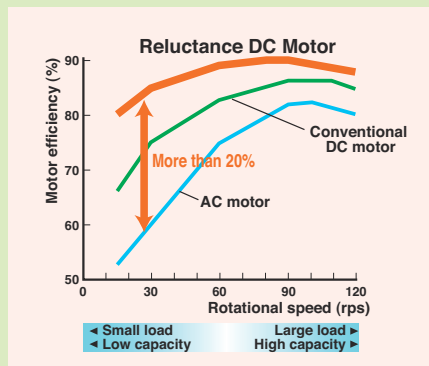

>> Smooth sine wave DC inverter

Use of an optimised sine wave smooths motor rotation, further improving operating efficiency.

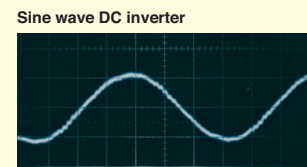

Note: Data are based on studies conducted under controlled conditions at a Daikin laboratory.

*1. A neodymium magnet is approximately 10 times stronger than a standard ferrite magnet.
*2. The torque created by the change in power between the iron and magnet parts.

RZQS50-71A, RZQ71/100L

>> Swing compressor

Energy savings is realised, eliminating the friction and the leakage of refrigerant gas.

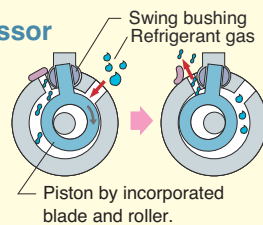

RZQS100-140A, RZQ125/140L

>> The structural scroll

Sucked gas is compressed in the scrolling part before the heated motor, so that the machine compresses the non-expanded gas, resulting in high efficiency compression.

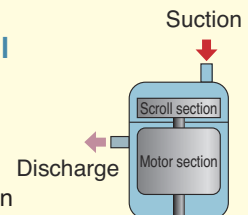

2 Smooth Air Inlet Bell Mouth and Aero Spiral Fan

These two features work to reduce noise. Guides are added to the bell mouth intake to reduce turbulence in the airflow generated by fan suction. The Aero Spiral Fan features fan blades with the bent blade edges, further reducing turbulence.

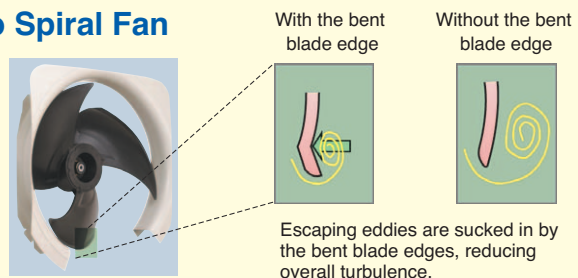

3 DC fan motor

Efficiency improved in all areas compared to AC motors, especially at low speeds.

DC fan motor structure

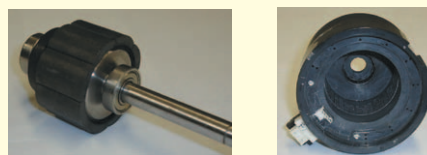

Easy-to-read LCD remote controller allows various system

Remote controller options are shown on the page introducing each indoor unit model.

Wired Remote Controller "Nav Ease"

NEW

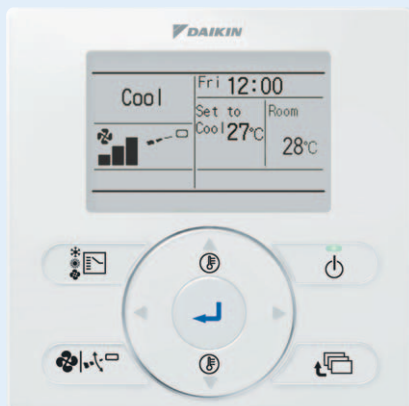

BRC1E62

This simple, contemporary remote controller with fresh white colour matches your interior design. The clear, backlight display with large easy-to-read text makes navigation easy and provides one-touch control over your in-home comfort.

Clear Display

Dot matrix display

A combination of fine dots enables various icons. Large text display is easy to see.

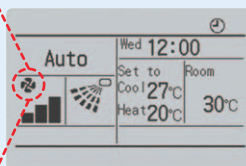
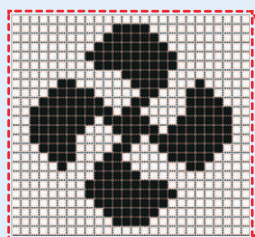

Backlight display

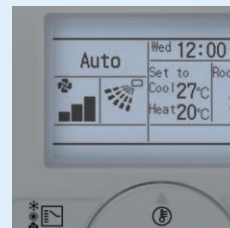

Energy saving

Auto operation mode

Until now only the temperature for one point could be set, but now the new remote controller (BRC1E62) allows the setting of both Cooling and Heating, and with the fan operation, mid-range temperatures are comfortable and operation is more energy efficient.

NEW 2 setpoints
Cooling / Heating

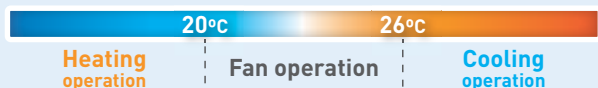
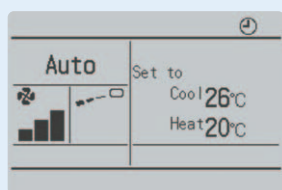

NEW Setpoint range set

- Saves energy by limiting the min. and max. set temperature.
- Avoids excessive heating or cooling.
- This function is convenient when the remote controller is installed at a place where any number of people may operate it.

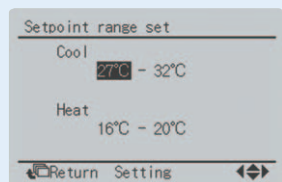

NEW Setpoint auto reset

- Even if the set temperature is changed, it returns to the preset temperature after a preset period of time.
- Period selectable from 30min/60min/90min/120min.

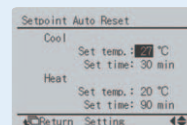



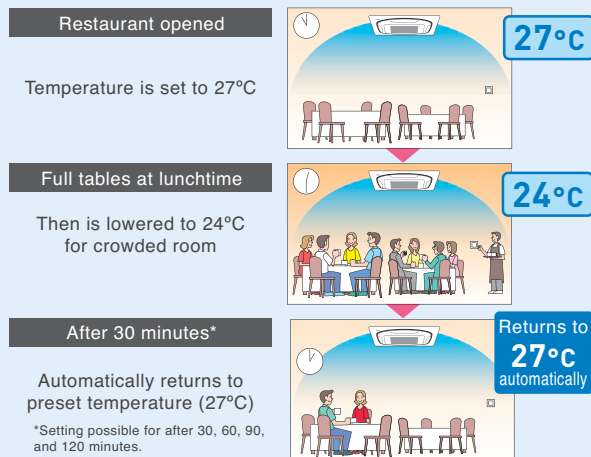







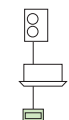

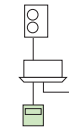
Restaurant sample

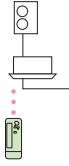

Off timer (programmed)

- Sets and saves setting for an increment of time that automatically turns off air conditioner after a preset period of time for each time operation starts.
- Period can be preset from 30 to 180 minutes in 10-minute increments.

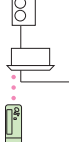
Simple system provides a diverse assortment of control modes.

	Control pattern	Wired remote controller	Wireless remote controller
Control by 1 remote controller	(Basic system)	 <ul style="list-style-type: none"> ● Non-polar, double-core (max. wiring length 500 m) 	 <ul style="list-style-type: none"> ● Signal receiver unit installed on indoor unit
Control by 2 remote controllers	For control from 2 locations such as in room and control room, exits, etc.	 <ul style="list-style-type: none"> ● Connects 2 wired remote controllers (See note 1) 	 <ul style="list-style-type: none"> ● Not possible (See note 2, 3)
Group control	For simultaneous control of up to 16 indoor units.	 <ul style="list-style-type: none"> ● Automatic address setting function 	 <ul style="list-style-type: none"> ● Automatic address setting function ● Signal receiver unit installed on 1 indoor unit
Control by external command	Operation and surveillance is carried out using the contact signal from the operation control box in the building surveillance (security) room.	 <ul style="list-style-type: none"> ● Optional wiring adaptor for electrical appendices is necessary 	 <ul style="list-style-type: none"> ● Optional wiring adaptor for electrical appendices is necessary
Centralised remote control	Centralised control of up to 64 indoor groups from remote location up to 1 kilometer away.	 <ul style="list-style-type: none"> ● Central remote controller (option) ● Optional SkyAir series interface adaptor required (See note 4) 	 <ul style="list-style-type: none"> ● Central remote controller (option) ● Optional SkyAir series interface adaptor required (See note 4)
Interlock control with Heat Reclaim Ventilator	Link by remote controller group control.	 <ul style="list-style-type: none"> ● Can be operated simultaneously or independently by remote controller (set by ventilation mode) 	 <ul style="list-style-type: none"> ● Can be operated simultaneously by remote controller (set by ventilation mode)
	Zone link control by centralised control.	 <ul style="list-style-type: none"> ● Central remote controller (option) ● Heat Reclaim Ventilator for indoor units within a zone are operated by interlocking. Can also be operated independently by remote controller. 	 <ul style="list-style-type: none"> ● Central remote controller (option) ● Heat Reclaim Ventilator for indoor units within a zone are operated by interlocking

Note: ¹.BRC1E62 can connect to BRC1E62 only.

².It is not possible to use two wireless remote controllers.

³.BRC1E62 cannot connect to wireless remote controller.

⁴.The ceiling mounted cassette type < Round Flow >, ceiling suspended type (140CA only), and wall mounted type come standard with an interface adaptor for SkyAir series.

Easily adaptable to large-scale, high-function, centralised remote control system.

Central remote controller

DCS302CA61 (Option)



Centralised control, with a setting as simple as it is with a standard remote controller, of up to 64 groups (1,024 indoor units) is possible.

Unified on/off controller

DCS301BA61 (Option)



Centralised control of on/off by group or all at once for up to 256 indoor units.

Schedule timer

DST301BA61 (Option)



Unified control of weekly schedule for up to 1,024 indoor units. Schedule timer sets on/off time in 1 minute units to be executed twice a day for a week at a time.

touch Intelligent Controller

DCS601C51 (Option)



With its high functionality, the full colour "all-in-one" graphic controller facilitates management of SkyAir System in a variety of ways.

Interface adaptor for SkyAir series

DTA112BA51 (Option)

Enables centralised control via connection to a high-speed, DIII-NET communication system, adopted for the Daikin VRV system.

Necessary for interface adaptor for SkyAir series with the central remote control units shown at above.

● The interface adaptor for the SkyAir series is optional except for the ceiling mounted cassette type < Round Flow >, ceiling suspended type (140CA only), and wall mounted type.

Abundance of features that provide comfortable air-conditioning in stores and offices.

• Note: Some features only available on selected models. See model pages for full list of features applicable to each unit.

Comfort

Auto-swing

Delivers comfortable air-conditioning to all areas, near to and far from the air-conditioner.

■ The air flow direction can be fixed at your desired angle by the remote controller.

Swing pattern selection

(standard, ceiling soiling prevention)

You can freely set 2 air discharge settings by remote controller.

(1) Air direction in standard setting

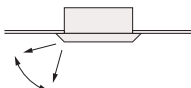

(2) Air direction in ceiling soiling prevention setting

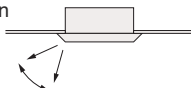

Draft prevention function (heating)

To prevent cold air drafts, automatically adjusts airflow to near horizontal position when heating initially starts or when the thermostat turns off.

Switchable fan speed

High setting provides maximum reach while low setting minimises drafts.

Auto airflow rate

Airflow rate is automatically controlled in accordance with the difference between room temperature and set temperature.

High fan speed mode

• Applicable for wall mounted type.

You can increase fan speed approximately 10% higher than the "high" setting.

Programme "Dry"

Dehumidification is a microprocessor controlled to prevent abrupt and uncomfortable changes in air temperature. Useful for reducing uncomfortable humidity without uncomfortable cooling of the room.

High-ceiling application

• Applicable for ceiling mounted cassette type and ceiling suspended type.

Delivers air-conditioning comfort all the way down to the floor in air-conditioning zones with high ceilings.

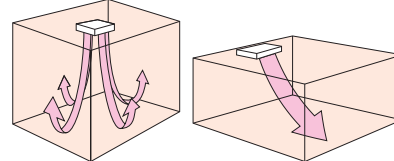

Note: When units are installed on high ceilings, depending on the model, various restrictions concerning maximum height, air discharge direction, and choice of options may apply.

Two selectable temperature-sensors

Temperature-sensors are included in the indoor unit and optional wired remote controller. Temperature sensing closer to the target area is possible to further increase the comfort level.

● Use the temperature-sensor in the indoor unit when controlling air conditioning from another room.

Note: Wireless remote controllers have no temperature-sensor.

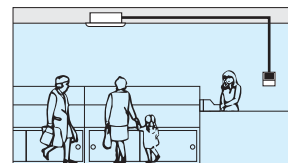

Hot start (after defrost)

Cold air flow is avoided when heating operation starts or when switching to heat after defrosting.

Year-round cooling applicable

Efficient cooling even in winter when the indoor temperatures are higher than those outside, such as in underground public spaces or offices with many computers.

Night quiet operation

The Automatic night quiet mode will initiate 8 hours after the peak temperature is reached in the daytime, and normal operation will resume 10 hours after that.

Remote Controller

Setpoint auto reset

Even if the set temperature is changed, it returns to the preset temperature after a preset period of time.

Setpoint range set

Saves energy by limiting the minimum and maximum set temperatures. Avoids excessive heating and cooling.

Weekly schedule timer

Up to five operation ON/OFF settings can be programmed per day for each day of the week. Not only can the time be set for the operation ON setting, but also the temperature.

Off timer (programmed)

Sets and saves setting for an increment of time that automatically turns off air conditioner after a preset period of time for each time operation starts.

Cleanliness

Anti-bacterial air filter

The Air filter has a anti-bacterial treatment to help prevent the growth of bacteria and mould on it.

Mould-proof air filter

Sanitary filter has mould-resistant treatment.

Silver ion anti-bacterial drain pan

Mould-proof drain pan includes a silver ion antibacterial agent that assists in preventing the growth of slime, bacteria, and mould that cause smells and clogging.

• Note: Some features only available on selected models. See model pages for full list of features applicable to each unit.

Work and Servicing

■ Drain pump mechanism

• Applicable for ceiling mounted cassette type and ceiling suspended type.

Steeper gradient realises more efficient condensate drainage. High-lift is especially useful for long lengths of drain piping.

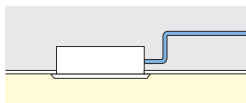

■ Pre charged for up to 30 metres

If the refrigerant piping length does not exceed 30 m, there is no need for on-site gas charging.

■ Filter sign

The filter sign warns you when it is time to clean the filter.

*When using a wired remote controller the sign is displayed in the LCD. When using a wireless remote controller the filter sign lamp illuminates on the signal receiver unit.

■ Ceiling soiling prevention function

• Applicable for ceiling mounted cassette type.

Daikin's innovative air discharge mechanism keeps airflow away from the ceiling. Ceiling cleaning is less frequently required.

■ Low gas pressure detection

Insufficient gas charging is normally hard to detect. During post-installation trials and regular inspection procedures, the refrigerant level is monitored by a microprocessor to maintain proper gas pressure. Reliability is assured and maintenance and inspection can be carried out more quickly.

■ Emergency operation

If there is a malfunction elsewhere in the system, the fan or compressor can still be operated.

■ Self diagnosis function

The operating parameters of indoor and outdoor units, and sensor data at critical locations throughout the system, are constantly monitored using a microcomputer. To facilitate a quick response in the event of a malfunction, a message appears on the LCD of the remote controller and an LED on the unit illuminates.

Control features

■ Auto-restart

If there is a power outage while the equipment is operating, operations will restart in the same mode as before the power cut when electricity is restored.

■ Auto cooling/heating change-over (Heat pump only)

Detects difference in preset temperature and actual room temperature and automatically switches to cooling or heating accordingly.

■ Control by 2 remote controllers

Using 2 remote controllers you can operate the equipment locally or from a remote location.

Note: When a wireless remote controller is used, remote control by two remote controllers is not possible.

■ Group control by 1 remote controller

You can turn up to 16 indoor units on/off with a single remote controller. (When using connected indoor units, the settings must all be the same and on/off will be simultaneous.)

■ External command control

Operation and surveillance is carried out using the contact signal from the operation control box in the building surveillance (security) room.

*An option is required.

■ Central remote control

An optional central remote controller enables centralised control of up to 1024 indoor units (64 groups) from up to 1 kilometer away.

■ Interlock control

Enables interlocking control with external equipment such as Heat Reclaim Ventilator.

■ DIII-NET communication standard

Standardly equipped interface enables connection to centralised control system without need of an adaptor.

Options

■ High-efficiency filter unit

• Applicable for ceiling mounted cassette type.

Two types are available: 65% and 90% colorimetry.

■ Fresh-air intake kit

• Applicable for ceiling mounted cassette type.

You can provide air-conditioning with fresh air from outside.

Convenient for places where a ventilation fan cannot be installed.

Note: *Connecting ducts, insect nets, fire dampers, air filters, and other parts should, as required, be procured locally.

**Outside Air fan interlocked with air conditioning unit is necessary. Optional PCB(KRP1C63)is required for interlocking.

***It is recommended that the volume of outdoor air introduced through the kit is limited to 10% of the maximum airflow rate of the indoor unit. Introducing higher quantities will increase the operating noise and may also influence temperature sending.

Others

■ Anti corrosion treated heat exchangers

To achieve increased durability by improved resistance to salt corrosion and atmospheric pollution, coated Anti corrosion treated heat exchangers (with special acryl pretreatment) are used for the heat exchanger of the outdoor unit.

In high corrosive areas, regular maintenance needs to be carried out.

SPECIFICATIONS

CEILING MOUNTED CASSETTE TYPE



		50	60	71	100	125	140	100	125	140					
Model Name	Indoor unit	FCQ50KAVEA	FCQ60KAVEA	FCQ71KAVEA	FCQ100KAVEA	FCQ125KAVEA	FCQ140KAVEA	FCQ100KAVEA	FCQ125KAVEA	FCQ140KAVEA					
	Outdoor unit	RZQS50AV1	RZQS60AV1	RZQS71AV1	RZQS100AV1	RZQS125AV1	RZQS140AV1	RZQS100AY1	RZQS125AY1	RZQS140AY1					
Power supply		1 Phase, 220-240 V, 50 Hz					3 Phase, 380-415 V, 50 Hz								
Cooling capacity ^{1,3} Rated (Min. - Max.)		kW		5.0 (3.2-5.6)	6.0 (3.2-6.0)	7.1 (3.2-8.0)	10.0 (5.0-11.2)	12.5 (5.7-14.0)	14.0 (6.2-15.5)	10.0 (5.0-11.2)	12.5 (5.7-14.0)	14.0 (6.2-15.5)			
Heating capacity ^{2,3} Rated (Min. - Max.)		kW		6.0 (3.5-7.0)	7.0 (3.5-8.0)	8.0 (3.5-9.0)	11.2 (5.1-12.8)	14.0 (6.0-16.2)	16.0 (6.2-18.0)	11.2 (5.1-12.8)	14.0 (6.0-16.2)	16.0 (6.2-18.0)			
Power consumption		kW		1.27	1.67	1.84	2.57	3.56	4.40	2.57	3.56	4.40			
		kW		1.41	1.74	1.79	2.77	3.60	4.38	2.77	3.60	4.38			
EER		kW/kW		3.94	3.59	3.85	3.89	3.51	3.18	3.89	3.51	3.18			
COP		kW		4.26	4.02	4.46	4.05	3.89	3.65	4.05	3.89	3.65			
Indoor unit	Colour	Fresh white													
	Unit	Fresh white													
	Decoration panel	Fresh white													
	Airflow rate (H/M/L)	ℓ/s		350/292/225			533/433/333		550/467/375		533/433/333		550/467/375		
		m ³ /min		21/17.5/13.5			32/26/20		33/28/22.5		32/26/20		33/28/22.5		
	Sound pressure level (H/M/L) ⁴	dB(A)		35/31.5/28			43/37.5/32		44/39/34		43/37.5/32		44/39/34		
	Sound power level (H/L) ⁵	dB(A)		53/46			60/50		61/52		61/54		60/50		
	Dimensions (H×W×D)	Unit		mm			256×840×840		298×840×840		50×950×950		298×840×840		
	Machine weight	Unit		kg			21		24		5.5		24		
		Unit		kg			21		24		5.5		24		
Certified Operation range	Cooling		°CWB		14 to 25										
	Heating		°CDB		15 to 27										
Outdoor unit	Colour	Ivory white													
	Compressor	Type		Hermetically sealed swing type					Hermetically sealed scroll type						
		Motor output		kW		1.3		1.6		1.55		3.15			
	Refrigerant charge (R-410A)	kg		2.0 (Charged for 30 m)		2.9 (Charged for 30 m)		4.0 (Charged for 30 m)		4.2 (Charged for 30 m)		4.0 (Charged for 30 m)		4.2 (Charged for 30 m)	
	Sound pressure level	Cooling/Heating ⁴		dB(A)		48/50		50/52		53/55		54/56		53/55	
		Night quiet mode		dB(A)		44		46		49		50		49	
	Sound power level ⁵	dB(A)		66		69		69		69		69		69	
	Dimensions (H×W×D)	mm		770×900×320			990×940×320			1,430×940×320					
	Machine weight	kg		64			75			108					
	Certified Operation range	Cooling		°CDB		-5 to 46									
Heating		°CWB		-15 to 15.5											
Piping connections	Liquid (Flare)		mm		ø9.5										
	Gas (Flare)		mm		ø15.9										
	Drain	Indoor unit		mm		VP25 (I.D.ø25×O.D.ø32)									
		Outdoor unit		mm		ø26.0 (Hole)									
Max. interunit piping length		m		50 (Equivalent length 70)					75 (Equivalent length 90)						
Max. installation level difference		m		30											
Heat insulation		Both liquid and gas piping													

Inverter series

		71	100	125	140								
Model Name	Indoor unit	FCQ71KAVEA	FCQ100KAVEA	FCQ125KAVEA	FCQ140KAVEA								
	Outdoor unit	RZQ71LV1	RZQ100LV1	RZQ125LV1	RZQ140LV1								
Power supply		1 Phase, 220-240 V, 50 Hz											
Cooling capacity rated (Min. - Max.) ^{1,3}		kW		7.1 (3.2-7.1)	10.0 (5.0-10.0)	12.5 (5.7-12.5)	13.6 (6.2-14.0)						
Heating capacity rated (Min. - Max.) ^{2,3}		kW		8.0 (3.5-8.0)	11.2 (5.1-12.5)	14.0 (6.0-15.0)	16.0 (6.2-16.5)						
Power consumption		kW		1.99	2.64	4.02	4.53						
		kW		2.10	2.84	3.83	4.80						
EER		kW/kW		3.57	3.79	3.11	3.00						
COP		kW		3.81	3.95	3.66	3.33						
Indoor unit	Colour	Fresh white											
	Unit	Fresh white											
	Decoration panel	Fresh white											
	Airflow rate (H/M/L)	ℓ/s		350/292/225		533/433/333		550/467/375					
		m ³ /min		21/17.5/13.5		32/26/20		33/28/22.5					
	Sound pressure level (H/M/L) ⁴	dB(A)		35/31.5/28		43/37.5/32		44/39/34					
	Sound power level (H/L) ⁵	dB(A)		53/46		60/50		61/52					
	Dimensions (H×W×D)	Unit		mm		256×840×840		298×840×840					
	Machine weight	Unit		kg		21		24					
		Unit		kg		21		24					
Certified Indoor Operation Range	Cooling		°CWB		14 to 25								
	Heating		°CDB		15 to 27								
Outdoor unit	Colour	Ivory white											
	Compressor	Type		Hermetically sealed swing type			Hermetically sealed scroll type						
		Motor output		kW		1.7		2.08		2.4		3.15	
	Refrigerant charge (R-410A)	kg		2.0 (Charged for 30 m)		2.9 (Charged for 30 m)		3.15 (Charged for 30 m)		4.2 (Charged for 30 m)			
	Sound pressure level	Cooling/Heating ⁴		dB(A)		49/51		51/53		54/56			
		Night quiet mode		dB(A)		45		47		50			
	Sound power level ⁵	dB(A)		66		69		69		69			
	Dimensions (H×W×D)	mm		770×900×320		990×940×320		1,170×900×320		1,430×940×320			
	Machine weight	kg		64		75		98		108			
	Certified Outdoor Operation Range	Cooling		°CDB		-5 to 46							
Heating		°CWB		-15 to 15.5									
Piping connections	Liquid (Flare)		mm		ø9.5								
	Gas (Flare)		mm		ø15.9								
	Drain	Indoor unit		mm		VP25 (I.D.ø25×O.D.ø32)							
		Outdoor unit		mm		ø26.0 (Hole)							
Max. interunit piping length		m		50 (Equivalent length 70)			75 (Equivalent length 90)						
Max. installation level difference		m		30									
Heat insulation		Both liquid and gas piping											

Note :

¹Rated cooling capacities are based on the following conditions: Indoor temp., 27°CDB, 19.0°CWB; outdoor temp. 35°CDB, 24°CWB. Equiv. refrigeration piping, 7.5 m (horizontal).

²Rated heating capacities are based on the following conditions: Indoor temp., 20°CDB, 15°CWB; outdoor temp., 7°CDB, 6°CWB. Equiv. refrigeration piping, 7.5 m (horizontal)

³Capacities are net, including a deduction for cooling for indoor fan motor heat.

⁴Anechoic chamber conversion value, measured according to JIS parameters and criteria. During operation these values are somewhat higher owing to ambient conditions.

⁵Numerical values are according to ISO 3741:1999.

SPECIFICATIONS

CEILING SUSPENDED TYPE



		71	100	125	140	100	125	140				
Model Name	Indoor unit	FHQ71BWW1A	FHQ100BWW1A	FHQ125BWW1A	FHQ140CAVEA	FHQ100BWW1A	FHQ125BWW1A	FHQ140CAVEA				
	Outdoor unit	RZQS71AV1	RZQS100AV1	RZQS125AV1	RZQS140AV1	RZQS100AY1	RZQS125AY1	RZQS140AY1				
Power supply		1 Phase, 220-240 V, 50 Hz				3 Phase, 380-415 V, 50 Hz						
Cooling capacity ^{1,3} Rated (Min. - Max.)		kW		5.8 (3.2-8.0)	9.2 (5.0-11.2)	11.2 (5.7-14.0)	13.2 (6.2-15.5)	9.2 (5.0-11.2)	11.2 (5.7-14.0)	13.2 (6.2-15.5)		
Heating capacity ^{2,3} Rated (Min. - Max.)		kW		7.5 (3.5-9.0)	10.5 (5.1-12.8)	13.5 (6.0-16.2)	16.0 (6.2-18.0)	10.5 (5.1-12.8)	13.5 (6.0-16.2)	16.0 (6.2-18.0)		
Power consumption		kW		1.77	2.85	3.56	4.34	2.85	3.56	4.34		
		kW		2.32	3.26	4.35	4.94	3.26	4.35	4.94		
EER		kW/kW		3.28	3.23	3.15	3.04	3.23	3.15	3.04		
COP		kW		3.23	3.22	3.10	3.24	3.22	3.10	3.24		
Indoor unit		Colour		White				White		Fresh white		
		Airflow rate (H/M/L)		ℓ/s	283-/233	400-/333	500-/417	567/483/400	400-/333	500-/417	567/483/400	
				m ³ /min	17-/14	24-/20	30-/25	34/29/24	24-/20	30-/25	34/29/24	
				dB(A)	39-/35	42-/37	44-/39	46/42/38	42-/37	44-/39	46/42/38	
				dB(A)	55-/51	58-/53	60-/55	64/60/56	58-/53	60-/55	64/60/56	
		Dimensions (H×W×D)		mm	195×1,160×680	195×1,400×680	195×1,590×680	235×1,590×690	195×1,400×680	195×1,590×680	235×1,590×690	
		Machine weight		kg	27	32	35	38	32	35	38	
		Certified Operation range		°CWB	14 to 25							
				°CDB	15 to 27							
Outdoor unit		Colour		Ivory white								
		Compressor		Type	Hermetically sealed swing type				Hermetically sealed scroll type			
				Motor output	kW				3.15			
		Refrigerant charge (R-410A)		kg	2.9 (Charged for 30 m)	4.0 (Charged for 30 m)	4.2 (Charged for 30 m)	4.0 (Charged for 30 m)	4.2 (Charged for 30 m)	4.0 (Charged for 30 m)	4.2 (Charged for 30 m)	
		Sound pressure level		dB(A)	50/52	53/55	54/56	53/55	54/56	53/55	54/56	
		Night quiet mode		dB(A)	46	49	50	49	50	46	49	
		Sound power level		dB(A)	69							
		Dimensions (H×W×D)		mm	990×940×320	1,430×940×320						
		Machine weight		kg	75	108						
		Certified Operation range		°CDB	-5 to 46							
				°CWB	-15 to 15.5							
Piping connections		Liquid (Flare)		mm	ø9.5							
		Gas (Flare)		mm	ø15.9							
		Drain		Indoor unit	VP20 (I.D.ø20×O.D.ø26)							
				Outdoor unit	ø26.0 (Hole)							
Max. interunit piping length		m		50 (equivalent length 70)	75 (equivalent length 90)							
Max. installation level difference		m		30								
Heat insulation		Both liquid and gas piping										

WALL MOUNTED TYPE



		71	100	100		
Model Name	Indoor unit	FAQ71CVEA	FAQ100CVEA	FAQ100CVEA		
	Outdoor unit	RZQS71AV1	RZQS100AV1	RZQS100AY1		
Power supply		1 Phase, 220-240 V, 50 Hz		3 Phase, 380-415 V, 50 Hz		
Cooling capacity ^{1,3} Rated (Min. - Max.)		kW		10.0 (5.0-11.2)		
Heating capacity ^{2,3} Rated (Min. - Max.)		kW		11.2 (5.1-12.8)		
Power consumption		kW		3.19		
		kW		3.44		
EER		kW/kW		3.13		
COP		kW		3.26		
Indoor unit		Colour			Fresh white	
		Airflow rate (H/M/L)		ℓ/s	300/267/233	
				m ³ /min	18/16/14	
		Sound pressure level (H/M/L) ⁴		dB(A)	45/42/40	
		Sound power level (H/M/L) ⁵		dB(A)	61/58/56	
		Dimensions (H×W×D)		mm	290×1,050×238	
		Machine weight		kg	13	
		Certified Operation range		°CWB	14 to 25	
				°CDB	15 to 27	
Outdoor unit		Colour			Ivory white	
		Compressor		Type	Hermetically sealed swing type	
				Motor output	kW	
					3.15	
		Refrigerant charge (R-410A)		kg	2.9 (Charged for 30 m)	
					4.0 (Charged for 30 m)	
		Sound pressure level		dB(A)	50/52	
		Night quiet mode		dB(A)	46	
		Sound power level		dB(A)	69	
		Dimensions (H×W×D)		mm	990×940×320	
		Machine weight		kg	75	
		Certified Operation range		°CDB	-5 to 46	
				°CWB	-15 to 15.5	
Piping connections		Liquid (Flare)		mm	ø9.5	
		Gas (Flare)		mm	ø15.9	
		Drain		Indoor unit	VP13 (I.D.ø13×O.D.ø18)	
				Outdoor unit	ø26.0 (Hole)	
Max. interunit piping length		m		50 (Equivalent length 70 m)	75 (Equivalent length 90 m)	
Max. installation level difference		m		30		
Heat insulation		Both liquid and gas piping				

Note :

¹Rated cooling capacities are based on the following conditions: Indoor temp., 27°CDB, 19.0°CWB; outdoor temp. 35°CDB, 24°CWB. Equiv. refrigeration piping, 7.5 m (horizontal).

²Rated heating capacities are based on the following conditions: Indoor temp., 20°CDB, 15°CWB; outdoor temp., 7°CDB, 6°CWB. Equiv. refrigeration piping, 7.5 m (horizontal).

³Capacities are net, including a deduction for cooling for indoor fan motor heat.

⁴Anechoic chamber conversion value, measured according to JIS parameters and criteria. During operation these values are somewhat higher owing to ambient conditions.

⁵Numerical values are according to ISO 3741:1999.

OPTIONS

Indoor unit

CEILING MOUNTED CASSETTE TYPE

Name of option	Remark	Kit name					
		FCQ50KAVEA	FCQ60KAVEA	FCQ71KAVEA	FCQ100KAVEA	FCQ125KAVEA	FCQ140KAVEA
Decoration panel		BYCP125K-W1					
Sealing material of air discharge outlet		KDBH55K160F					
Panel spacer		KDBP55H160FA					
Fresh air intake kit ¹	Chamber type	Without T-joint pipe and fan		KDDP55B160			
		With T-joint pipe, without fan		KDDP55B160K			
	Direct installation type	KDDP55X160					
Chamber connection kit ²		KKSJ55KA160					
Insulation kit for high humidity		KDTP55K80			KDTP55K160		
High-efficiency filter unit (including filter chamber)	(Colorimetric method 65%)	KAFP556B80			KAFP556B160		
	(Colorimetric method 90%)	KAFP557B80			KAFP557B160		
Replacement high-efficiency filter	(Colorimetric method 65%)	KAFP552B80			KAFP552B160		
	(Colorimetric method 90%)	KAFP553B80			KAFP553B160		
Filter chamber		KDDFP55B160					
Branch duct chamber		KDJP55B80			KDJP55B160		
Remote controller	Wireless type	Heat pump		BRC7F634F			
Navigation Remote Controller	Wired type ³ "Nav Ease"	BRC1E62					
Central remote controller ⁴		DCS302CA61					
Unified ON/OFF controller ⁴		DCS301BA61					
Schedule timer ⁴		DST301BA61					
Intelligent Touch Controller ⁴		DCS601C51					
Adaptor for wiring ⁵		KRP1C63					
Group control adaptor ⁵		KRP4AA53					
Installation box for adaptor PCB		KRP1H98					
Remote sensor (for indoor temperature)		KRCS01-4B					

Note: ¹Refer to page 10 for the details.

²Required for installing high-efficiency filter unit.

³Wiring for wired remote controller to be procured locally.

⁴The indoor unit is equipped standardly with the interface adaptor for SkyAir series. An option is unnecessary.

⁵Installation box for adaptor PCB (KRP1H98) is necessary.

Round flow type: List of optional parts required to achieve different flow patterns

For each flow pattern – all round, 4-way, 3-way, 2-way, branch duct connection – the compatibility of each independently installed option (shown in the column on the left) to accessory options (listed across the top of each table) is shown in the cells where the relevant row and column intersect. A circle (○) indicates compatibility, and a cross (×) indicates incompatibility. Any options not shown below are not suitable for independent or accessory installation.

All-round flow 4-way flow

Independently installable optional parts		Optional accessory parts					
		Panel spacer ¹	Wireless remote controller	Fresh air intake kit (Chamber type) ^{1,2}	Fresh air intake kit (direct mount)	High-humidity operation kit	High-efficiency filter ²
Panel/grille related	Panel spacer ¹		○	○	○	×	○
Operation control related	Wireless remote controller	○		○	○	○	○
Auxillary function related	Fresh air intake kit (Chamber type) ^{1,2}	○	○		×	×	○
	Fresh air intake kit (direct mount)	○	○	×		○	○
	High-humidity operation kit	×	○	×	○		×
Filter related	High-efficiency filter ²	○	○	○	○	×	

3-way flow 2-way flow

Independently installable optional parts		Optional accessory parts					
		Panel spacer ¹	Wireless remote controller	Fresh air intake kit (Chamber type) ^{1,2}	Fresh air intake kit (direct mount)	High-humidity operation kit	High-efficiency filter ²
Panel/grille related	Panel spacer ¹		○ ³	○ ³	○ ³	×	×
Operation control related	Wireless remote controller	○ ³		○	○	○	×
Auxillary function related	Fresh air intake kit (Chamber type) ^{1,2}	○ ³	○		×	×	×
	Fresh air intake kit (direct mount)	○ ³	○	×		○	×
	High-humidity operation kit	×	○	×	○		×

Branch duct connection

Independently installable optional parts		Optional accessory parts					
		Panel spacer ¹	Wireless remote controller	Fresh air intake kit (Chamber type) ^{1,2}	Fresh air intake kit (direct mount)	High-humidity operation kit	High-efficiency filter ²
Branch duct ¹ (Chamber type) (Round duct type)	1-way branch / unit 3-way flow	○	○	○	○ ⁴	×	×
	2-way branch / unit 2-way flow	×	○	○	○ ⁴	×	×
	1-way branch / unit 2-way flow	×	○	○	○ ⁴	×	×

¹In some cases, depending on how the unit is embedded in the ceiling, use of branch ducts and fresh air intake kits may not be possible. Before starting installation work make sure to check whether or not joint installation is possible. In particular, ensure that the lower fixing position caused by the addition of panel spacers is acceptable.

²Use a chamber connection kit if two different types of optional chamber are used together. In this case, the fresh air intake kit must be installed in the upper position.

³It is not possible to use panel spacers in a 2-way flow installation.

⁴It is not possible to install a branch duct on the same side to which a fresh air intake kit (direct mount) is installed.

OPTIONS

Indoor unit

CEILING SUSPENDED TYPE

Name of option	Remark	Kit name			
		FHQ71BWV1A	FHQ100BWV1A	FHQ125BWV1A	FHQ140CAVEA
Fresh air intake kit					KDDQ50A140
Drain pump kit			KDU50N125VE		KDU50P140VE
L-type piping kit (for upward direction)			KHFP5MA160		KHFP5N160
Remote controller	Wireless type		Heat pump	BRC7EA63W	BRC7GA53
Navigation Remote Controller	Wired type ¹ "Nav Ease"			BRC1E62	
Central remote controller			DCS302CA61 ²		DCS302CA61 ³
Unified ON/OFF controller			DCS301BA61 ²		DCS301BA61 ³
Schedule timer			DST301BA61 ²		DST301BA61 ³
Intelligent Touch Controller			DCS601C51 ²		DCS601C51 ³
Adaptor for wiring				KRP1BA54	
Wiring adaptor for electrical appendices ⁴				KRP4AA52	
Interface adaptor for SkyAir series			DTA112BA51		
Installation box for adaptor PCB			KRP1CA93		KRP1D93A
Remote sensor (for indoor temperature)			KRCS01-1B		KRCS01-4B
Electrical box with earth terminal (3 blocks)				KJB311AA	
Electrical box with earth terminal (2 blocks)				KJB212AA	

Note: ¹Wiring for wired remote controller to be procured locally.

²This optional accessory requires DTA112BA51.

³The indoor unit is equipped standardly with the interface adaptor for SkyAir series. An option is unnecessary.

⁴Installation box for adaptor PCB is necessary.

WALL MOUNTED TYPE

Name of option	Remark	Kit name	
		FAQ71CVEA	FAQ100CVEA
Drain-up kit			K-KDU572EVE
Remote controller	Wireless type		Heat pump
Navigation Remote Controller	Wired type ¹ "Nav Ease"		BRC1E62
Remote sensor (for Indoor temperature)			KRCS01-4B
Central remote controller ²			DCS302CA61
Unified ON/OFF controller ²			DCS301BA61
Schedule timer ²			DST301BA61
Intelligent Touch Controller ²			DCS601C51
Wiring adaptor for electrical appendices ³			KRP4AA51
Installation box for adaptor PCB			KRP4AA93
Electrical box with earth terminal (3 blocks)			KJB311AA
Electrical box with earth terminal (2 blocks)			KJB212AA
Noise filter (For electromagnetic interface use only)			KEK26-1A

Note: ¹Wiring for wired remote controller to be procured locally.

²The indoor unit is equipped standardly with the interface adaptor for SkyAir series. An option is unnecessary.

³Installation box for adaptor PCB (KRP4AA93) is necessary.

Outdoor unit

Name of option	Kit name					
	Heat pump					
	RZQS50AV1	RZQS60AV1	RZQS71AV1	RZQS100AV1	RZQS125AV1	RZQS140AV1
Central drain plug	KKPJ5F180		KKPJ5G280			
Wire fixture for preventing overturning	K-KYZP15C					
Fixture for preventing overturning	KPT-60B160		KKTP5B112			
Demand adaptor	KRP58M51					

Name of option	Kit name			
	RZQ71LV1	RZQ100LV1	RZQ125LV1	RZQ140LV1
Central drain plug	KKPJ5F180	KKPJ5G280	KKPJ5F180	KKPJ5G280
Wire fixture for preventing overturning	K-KYZP15C			
Fixture for preventing overturning	KPT-60B160	KKTP5B112	KPT-60B160	KKTP5B112
Demand adaptor	KRP58M51			

DIMENSIONS (Unit: mm)

CEILING MOUNTED CASSETTE TYPE

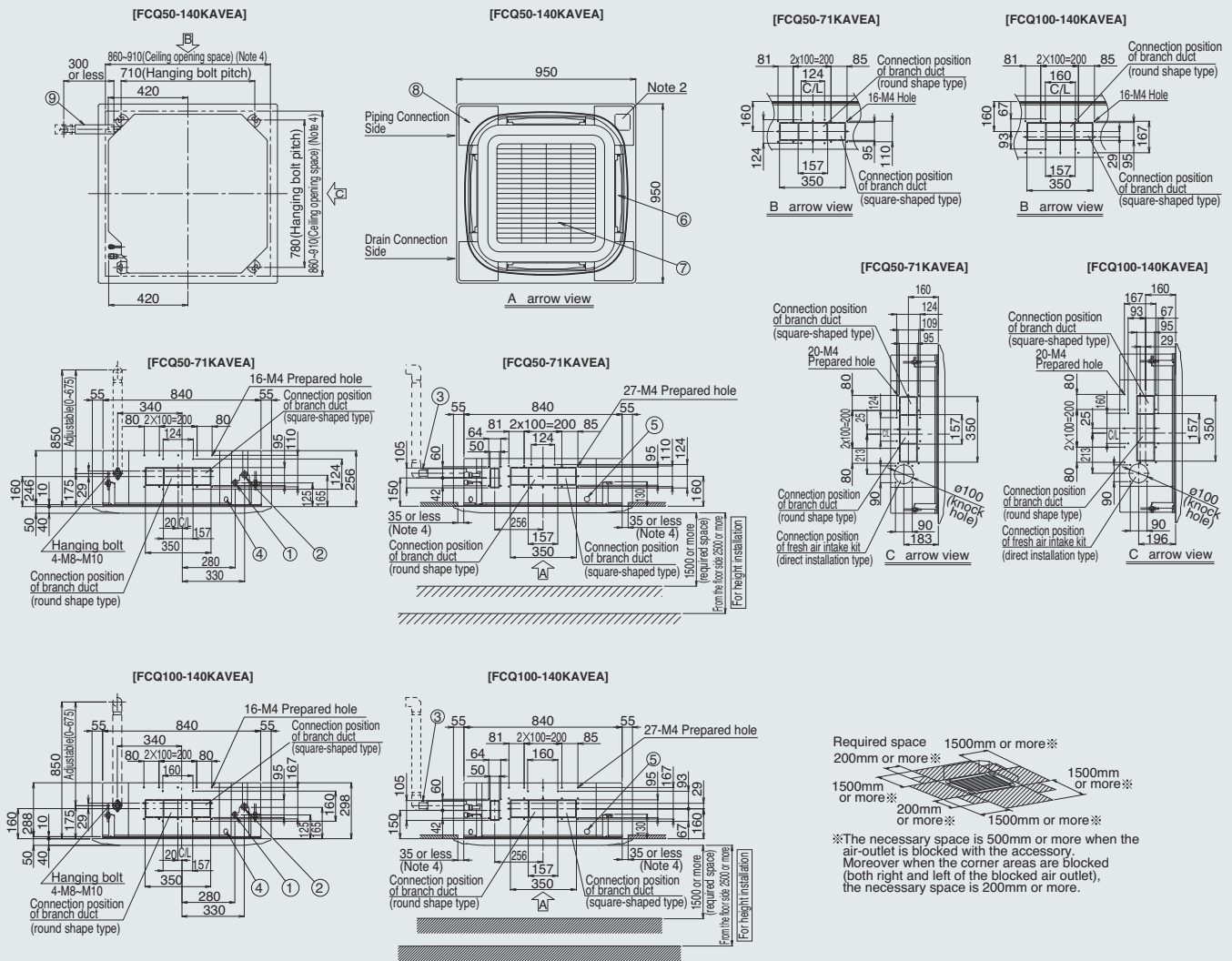

- ① Liquid pipe connection
- ② Gas pipe connection
- ③ Drain pipe connection
- ④ Transmission wiring connection
- ⑤ Remote controller wiring connection
- ⑥ Air-outlet
- ⑦ Suction grille
- ⑧ Corner decoration cover
- ⑨ Drain hose (accessory)

DIMENSIONS (Unit: mm)

CEILING SUSPENDED TYPE

[FHQ71-125BWV1A]

	A	B
FHQ71BWV1A	1120	1160
FHQ100BWV1A	1360	1400
FHQ125BWV1A	1550	1590

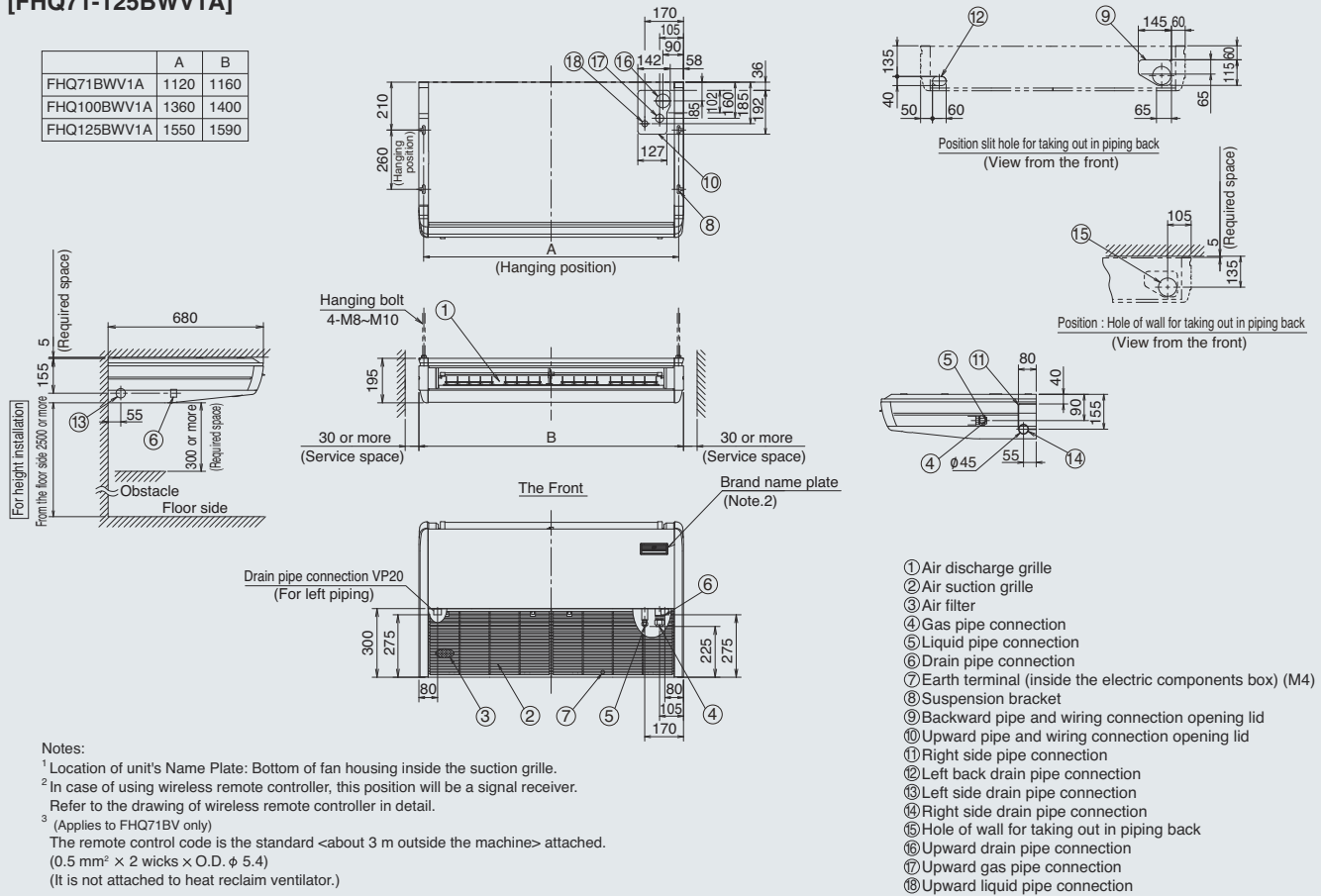

CEILING SUSPENDED TYPE

[FHQ140CAVEA]

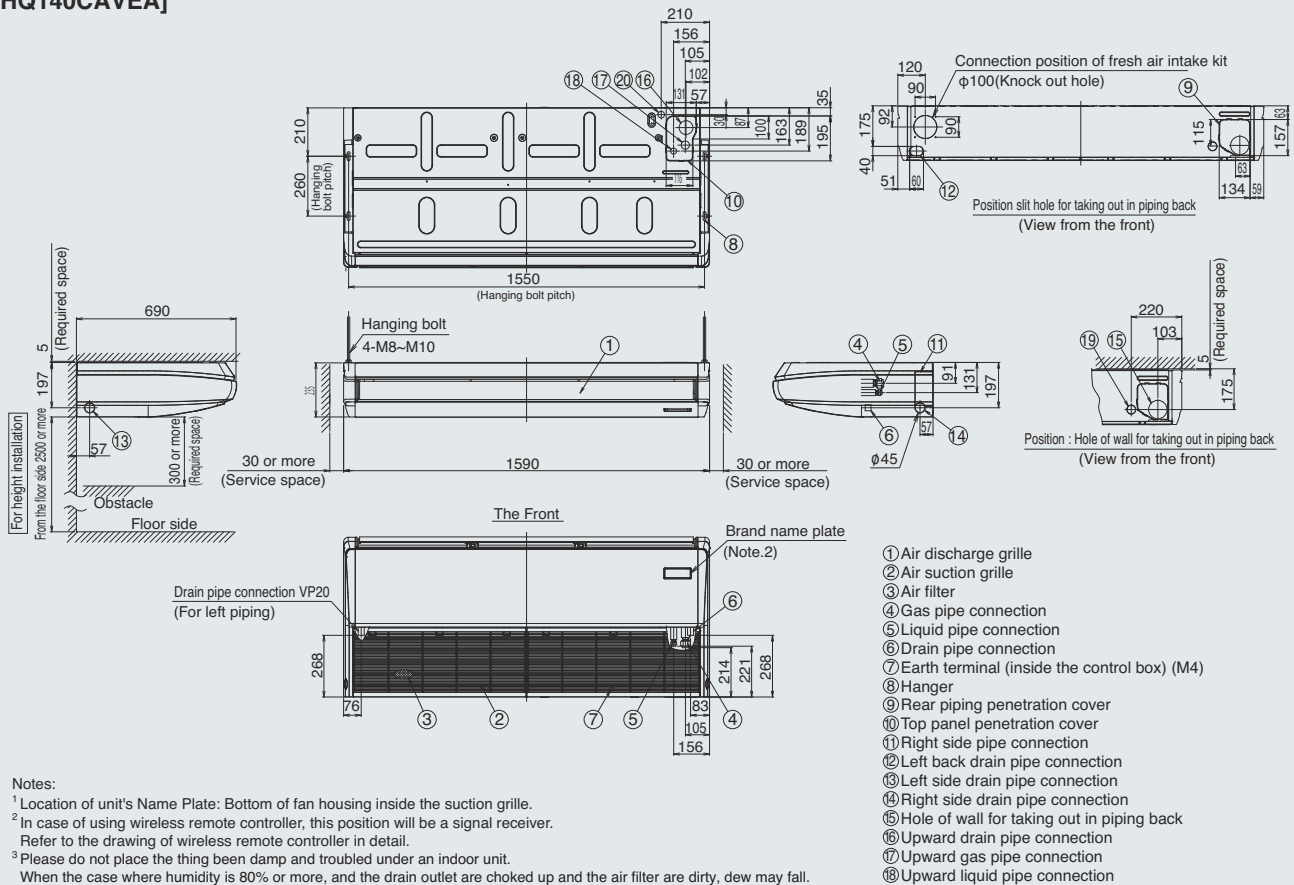

WALL MOUNTED TYPE

[FAQ71CVEA]

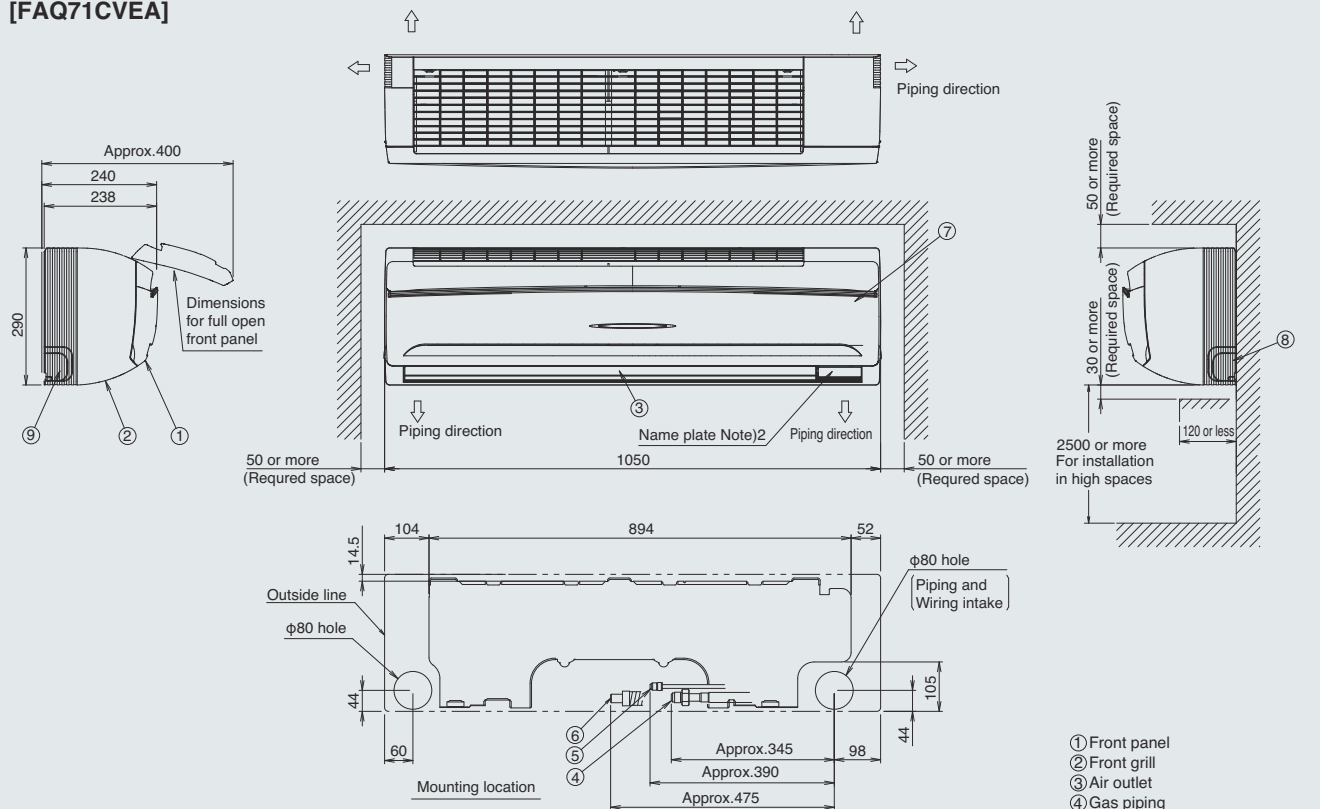

Notes:

- ¹ Location of unit's Name Plate: Right side surface of casing
- ² In case of using wireless remote controller, this position will be a signal receiver. Refer to the drawing of wireless remote controller in detail.
- ³ Please do not place the thing been damp and troubled under an indoor unit. when the case where humidity is 80% or more, and the drain outlet are choked up and the air filter are dirty, dew may fall.

- ① Front panel
- ② Front grill
- ③ Air outlet
- ④ Gas piping
- ⑤ Liquid piping
- ⑥ Drain hose
- ⑦ Earth terminal
- ⑧ Right side pipe connection hole
- ⑨ Left side pipe connection hole

WALL MOUNTED TYPE

[FAQ100CVEA]

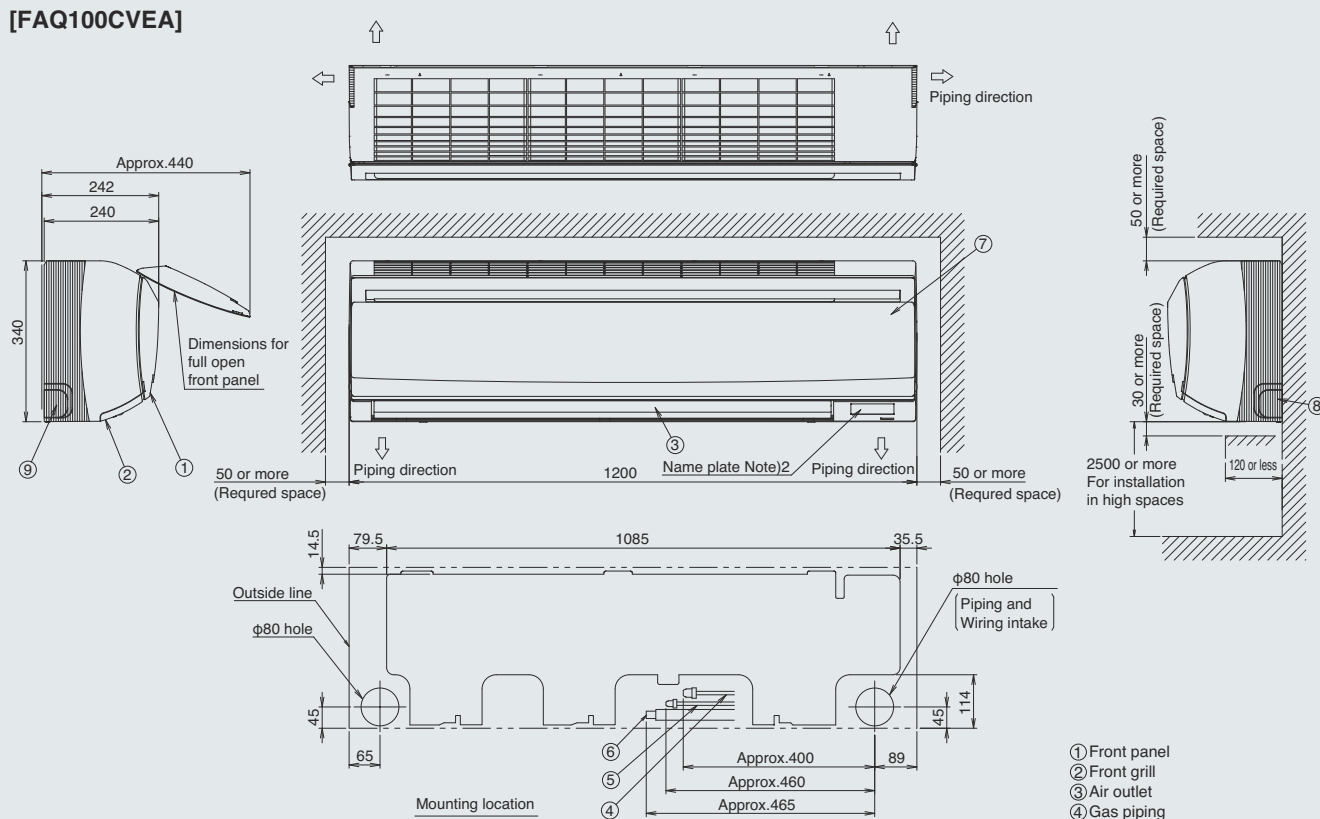

Notes:

- ¹ Location of unit's Name Plate: Right side surface of casing
- ² In case of using wireless remote controller, this position will be a signal receiver. Refer to the drawing of wireless remote controller in detail.
- ³ Please do not place the thing been damp and troubled under an indoor unit. when the case where humidity is 80% or more, and the drain outlet are choked up and the air filter are dirty, dew may fall.

- ① Front panel
- ② Front grill
- ③ Air outlet
- ④ Gas piping
- ⑤ Liquid piping
- ⑥ Drain hose
- ⑦ Earth terminal
- ⑧ Right side pipe connection hole
- ⑨ Left side pipe connection hole

DIMENSIONS (Unit: mm)

OUTDOOR UNIT // RZQS50/60AV1, RZQ71LV1

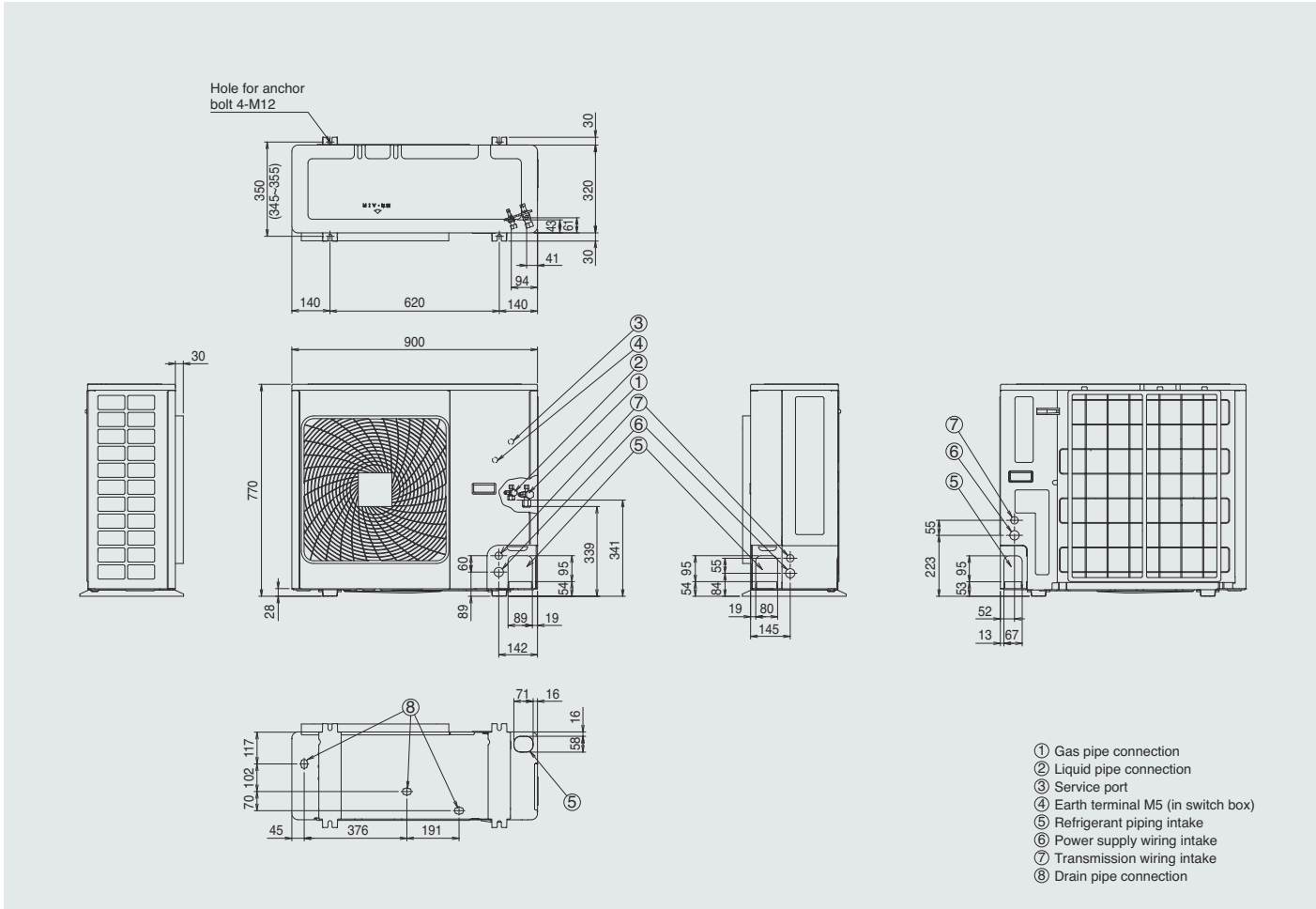

OUTDOOR UNIT // RZQS71AV1, RZQ100LV1

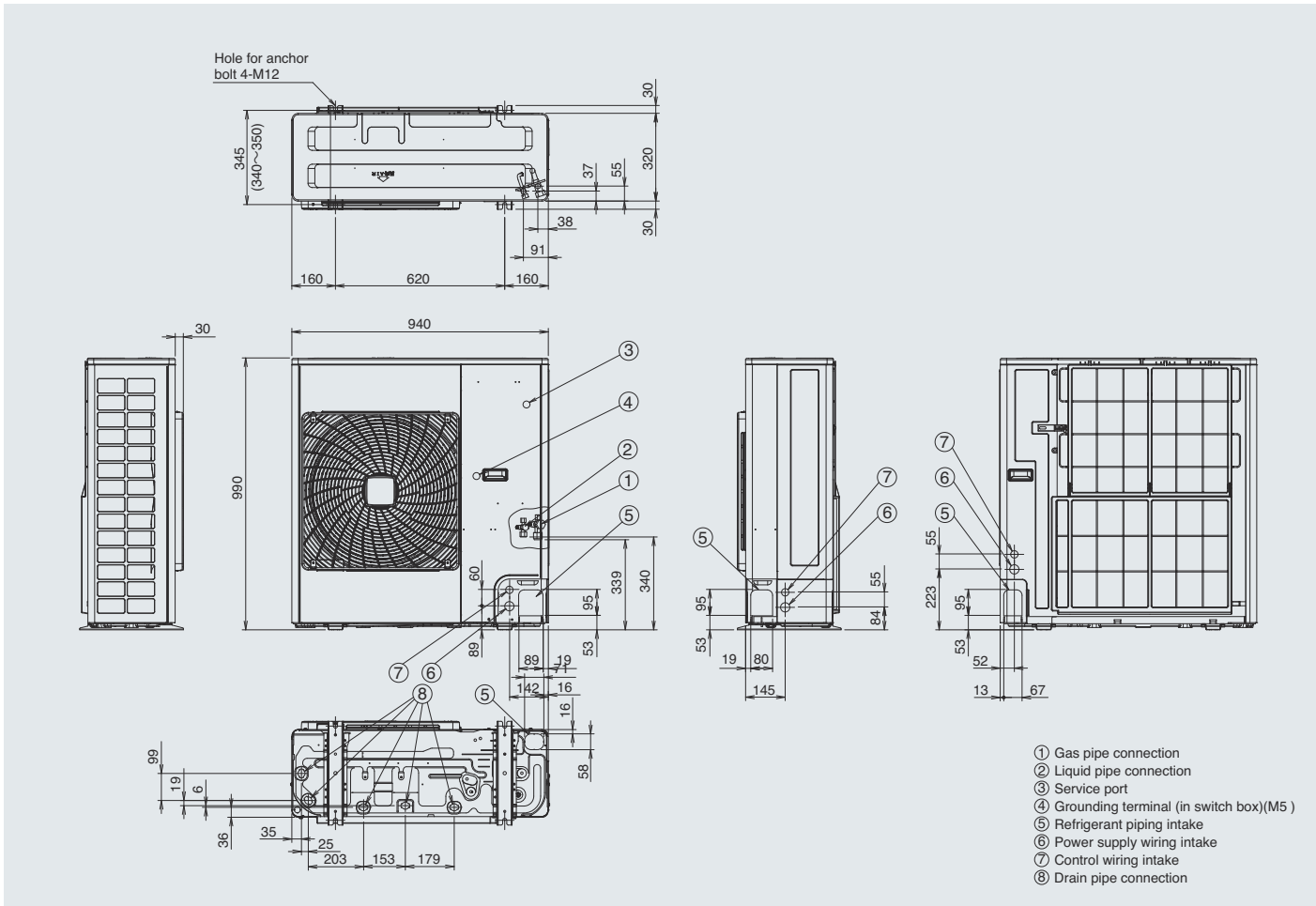

OUTDOOR UNIT // RZQ125LV1

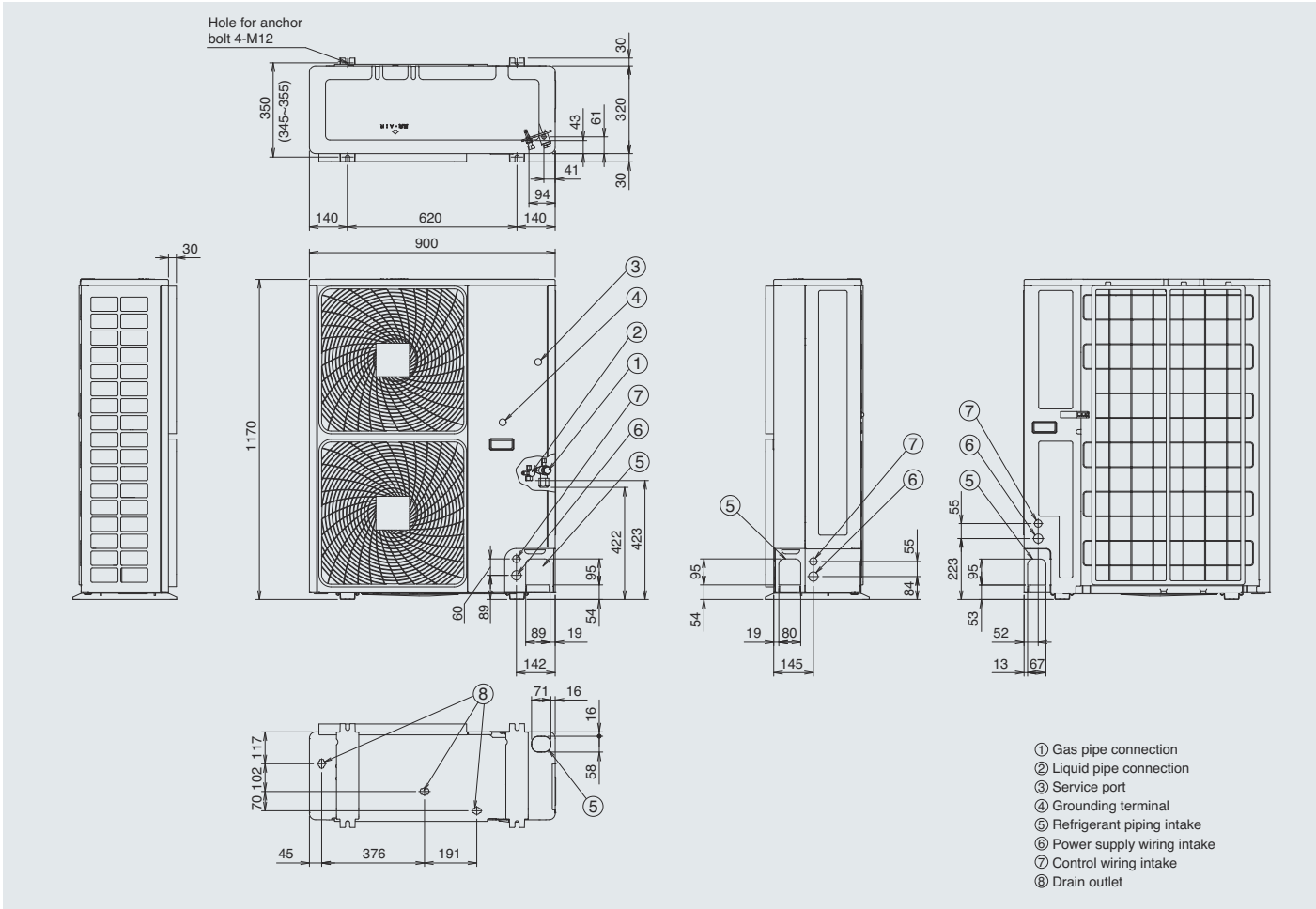

OUTDOOR UNIT // RZQS100/125/140AV1, RZQS100/125/140AY1, RZQ140LV1

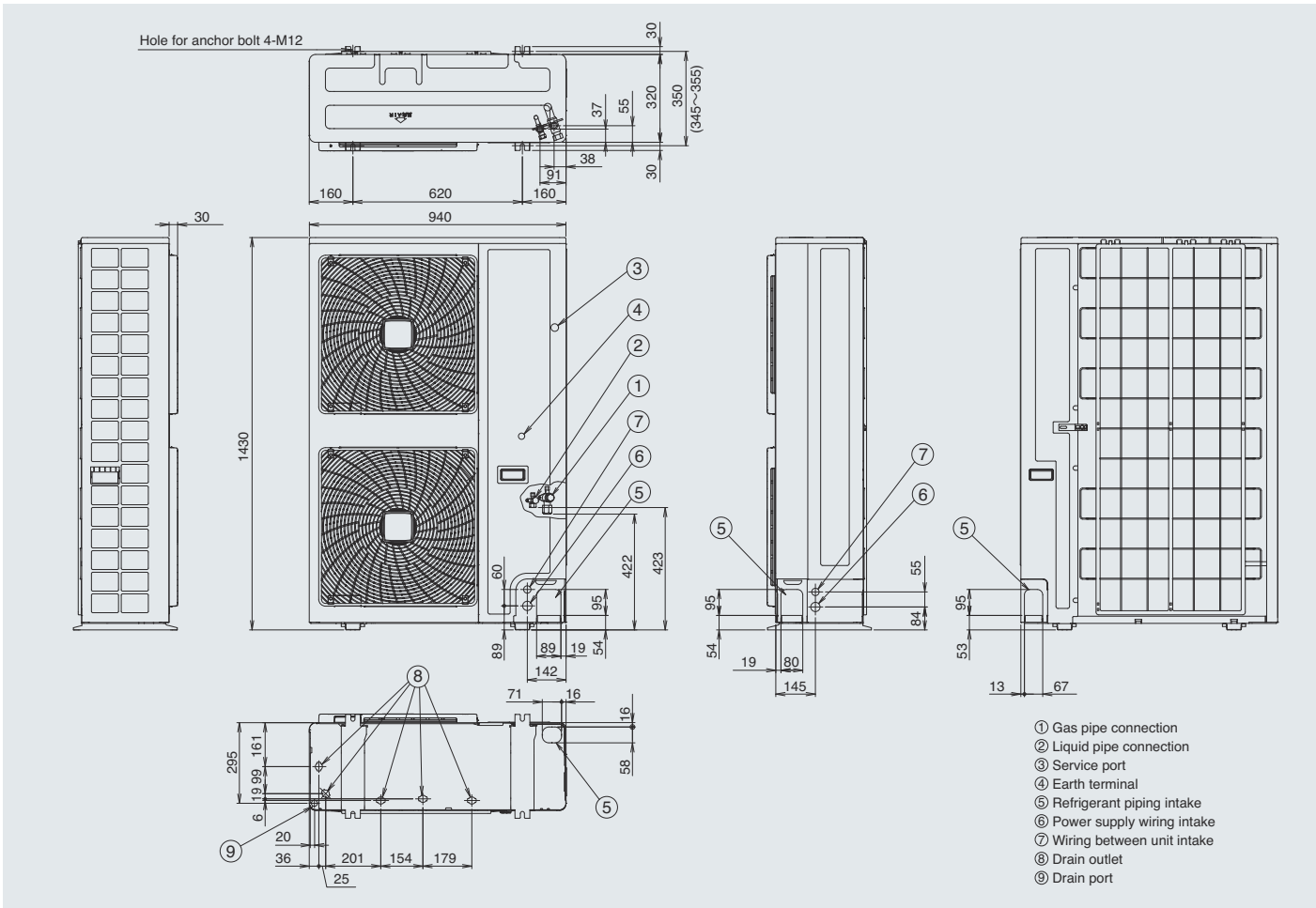

DIMENSIONS (Unit: mm)

REMOTE CONTROLLER

《Wireless type》

Remote controller dimensions

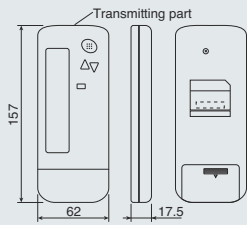

Remote controller holder installation procedure < installation to wall surface >

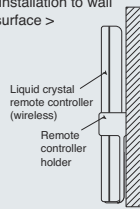

CEILING MOUNTED CASSETTE TYPE < Round Flow >

Receiver installation procedure

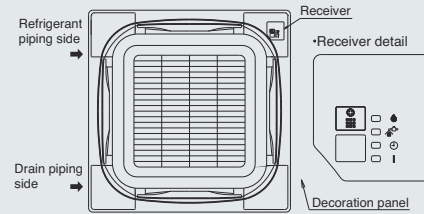

CEILING SUSPENDED TYPE

Receiver installation procedure

FHQ71-125BWV1A

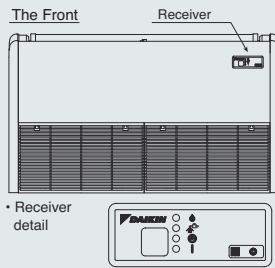

FHQ140CAVEA

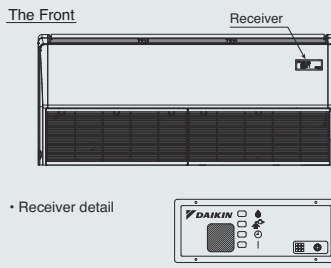

WALL MOUNTED TYPE

Receiver installation procedure

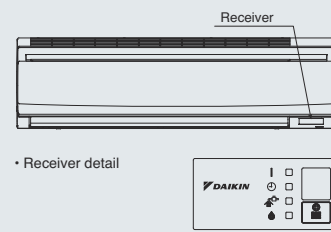

《Wired type》 Remote controller dimensions

BRC1E62

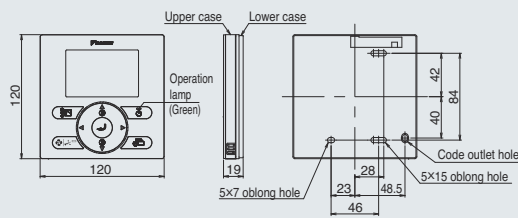

Installation method

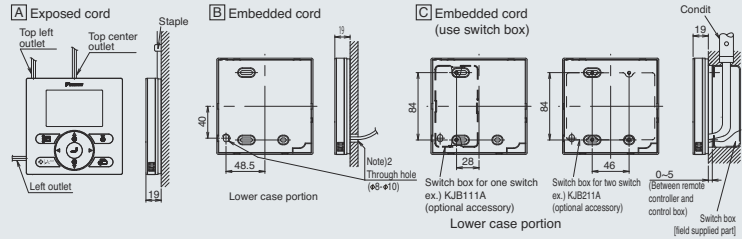

Note)

1. Remote controller cord and staple are not attached. They are field supplied parts.

Specifications of cord

Type	Vinyl cord with sheath or cable (insulated thickness: 1mm or more)
Size	0.75~1.25 mm ²
Total length	500 m

2. If the hole size is too large or the location is not proper, the hole may come out from the remote controller.

Installation service space for outdoor unit

■ For RZQS50-140AV1, RZQS100-140AY1, RZQ71-140LV1,

1 When there is an obstruction on the inlet side

1) When the overhead space is open

1. For single unit installation

When there is an obstruction only on the inlet side

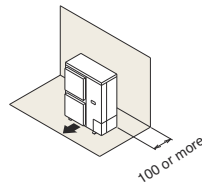

When there are obstructions on both sides

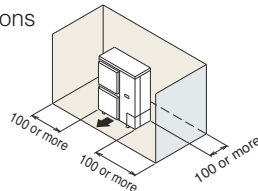

2. For series installation (more than two units)

When there are obstructions on both sides

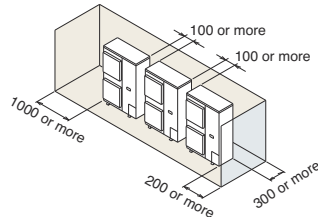

2) When there is an obstruction in the overhead space

1. For single unit installation

When there is an obstruction on the inlet side

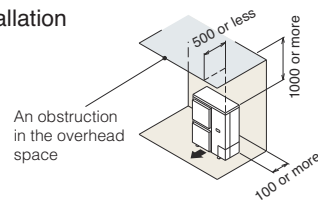

When there are obstructions on the inlet side and both lateral sides

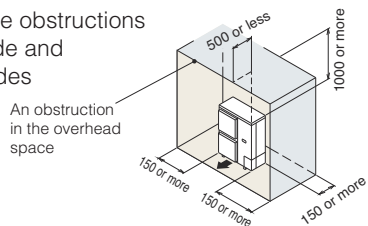

2. For series installation (more than two units)

When there are obstructions on the inlet side and both lateral sides

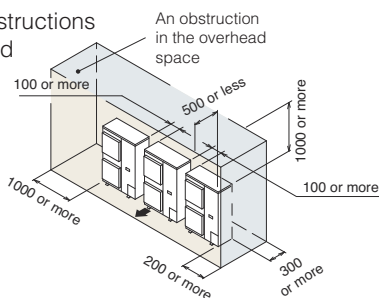

2) When there is an obstruction on the outlet side

1) When the overhead space is open

1. For single unit installation

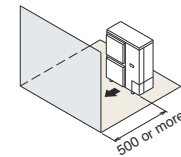

2. For series installation (more than two units)

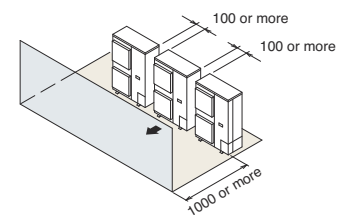

2) When there is an obstruction in the overhead space

1. For single unit installation

An obstruction in the overhead space

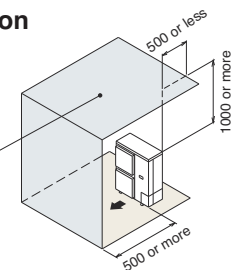

2. For series installation (more than two units)

An obstruction in the overhead space

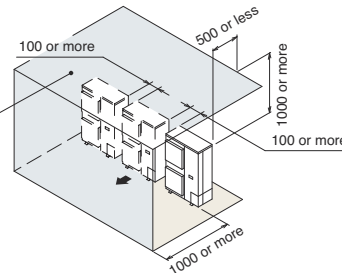

3) When there are obstructions on both the inlet and outlet sides

(When the obstruction on the outlet side is higher than the unit itself)

1) When the overhead space is open

(There is no limit to the height of the obstruction on the outlet side.)

1. For single unit installation

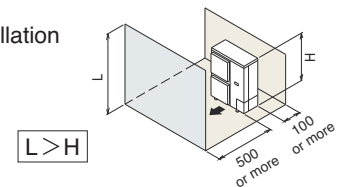

2. For series installation (more than two units)

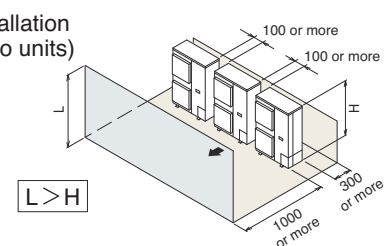

Note : As for other patterns of installation, please refer to Installation manual or Engineering Data Book.

MEMO



Warning



- Ask a qualified installer or contractor to install this product. Do not try to install the product by yourself. Improper installation can result in water or refrigerant leakage, electrical shock, fire or explosion.
- Use only those parts and accessories supplied or specified by Daikin. Ask a qualified installer or contractor to install those parts and accessories. Use of unauthorised parts and accessories or improper installation of parts and accessories can result in water or refrigerant leakage, electrical shock, fire or explosion.
- Read the user's manual carefully before using this product. The user's manual provides important safety instructions and warnings. Be sure to follow these instructions and warnings.

If you have any enquiries, please contact your local importer, distributor and/or retailer.

Cautions on product corrosion

1. Air conditioners should not be installed in areas where corrosive gases, such as acid gas or alkaline gas, are produced.
2. If the outdoor unit is to be installed close to the sea, direct exposure to sea breeze should be avoided. If you need to install the outdoor unit close to the sea, contact your local distributor.



JMI-0107

Organization:
DAIKIN INDUSTRIES, LTD.
AIR CONDITIONING MANUFACTURING
DIVISION

Scope of Registration:
THE DESIGN/DEVELOPMENT AND
MANUFACTURE OF COMMERCIAL AIR
CONDITIONING, HEATING, COOLING,
REFRIGERATING EQUIPMENT, HEATING
EQUIPMENT, RESIDENTIAL AIR
CONDITIONING EQUIPMENT, HEAT
RECLAIM VENTILATION, AIR CLEANING
EQUIPMENT, COMPRESSORS AND VALVES.



JQA-1452

Organization:
DAIKIN INDUSTRIES
(THAILAND) LTD.

Scope of Registration:
THE DESIGN/DEVELOPMENT
AND MANUFACTURE OF AIR
CONDITIONERS AND THE
COMPONENTS INCLUDING
COMPRESSORS USED FOR
THEM



Quality
ISO 9001

Daikin Australia
Pty Limited (ISO9001)
OEC23256 May 31, 2006
Sydney, Brisbane, Adelaide,
Melbourne, Newcastle,
Townsville, Perth, Auckland



Environment
ISO 14001

EC99J2044

All of the Daikin Group's business facilities and subsidiaries in Japan are certified under the ISO 14001 international standard for environment management.



Environment
ISO 14001

Daikin Australia
Pty Limited (ISO14001)
CEM20437 October 27, 2006
Sydney, Brisbane, Melbourne,
Adelaide

Dealer

DAIKIN INDUSTRIES, LTD.

Head Office:
Umeda Center Bldg., 2-4-12, Nakazaki-Nishi,
Kita-ku, Osaka, 530-8323 Japan

Tokyo Office:
JR Shinagawa East Bldg., 2-18-1, Konan,
Minato-ku, Tokyo, 108-0075 Japan

http://www.daikin.com/global_ac/

© All rights reserved
09/12 DN

• Specifications, designs and other content appearing in this brochure are current as of May 2015 but subject to change without notice.